

I.O.M. #103 1/08

INSTRUCTION MANUAL • INSTALLATION • OPERATION • MAINTENANCE

O.A.C.S.

CENTRAL CHILLER



All Models



ADVANTAGE ENGINEERING, INC.
525 East Stop 18 Road Greenwood, IN 46142
317-887-0729 fax: 317-881-1277
Service Department fax: 317-885-8683
www.AdvantageEngineering.com
e-mail: service@AdvantageEngineering.com



INSTRUCTION MANUAL

OACS Central Chillers

COVERING

INSTALLATION

OPERATION

MAINTENANCE



ADVANTAGE ENGINEERING, INC. 525 East Stop 18 Road Greenwood, IN 46142
317-887-0729 fax: 317-881-1277 Service Department fax: 317-885-8683
website: www.AdvantageEngineering.com e-mail: service@AdvantageEngineering.com

TABLE OF CONTENTS

1.0	GENERAL	7
1.1	Introduction	8
1.2	Warning labels	8
1.3	Efficiency	8
1.4	Safety	8
1.5	Clean air act	9
1.6	Miscellaneous	9
1.7	About the OACS chiller	9
1.8	Examine for shipment damages	10
1.9	Preparing unit for operations	10
2.0	INSTALLATION	13
2.1	General	14
2.2	Location	13
2.3	To and From process connections	14
2.4	Electrical connection	15
3.0	OPERATIONS	17
3.1	General	18
3.2	Start up/operations procedure	19
3.3	Instrument/operation : M1 controller	22
3.4	Instrument/operation : MKLE controller	26
3.5	Instrument/operation : Multizone controller	33
3.6	Shut down procedure	45
4.0	TROUBLESHOOTING	47
4.1	Unit Will Not Start	48
4.2	Compressor Will Not Start	48
4.3	Shuts Off On High Pressure	48
4.4	Shuts Off On Low Pressure	49
4.5	Compressor Shuts Off On Internal Overload	49
4.6	Low Or No Process Pressure Or Water Flow	50
4.7	Cooling Capacity Inadequate	50
4.8	Sensor	50
4.9	Coolant Pump	50
4.10	Oil Pressure	51
4.11	Crankcase Heater	51
4.12	Chiller Controller	51
5.0	MAINTENANCE	53
5.1	Warranty service procedure	54
5.2	Periodic preventative maintenance	54
5.3	Special maintenance	55
5.4	Solenoid valve service	56
5.5	Pump seal service	58
5.6	Checking the refrigerant charge	61
5.7	Proper cleaning procedure for brazed plate evaporators	61

6.0	COMPONENTS	63
6.1	Water system	64
6.2	Refrigeration system	64
7.0	RELATED DRAWINGS	67
7.1	Typical Circuit Schematic	68
7.2	Typical Physical Drawing	69
7.3	Electrical Drawing	70
7.4	Typical press drop	71
7.5	Typical vacuum breaker anti siphon system	72
7.6	Typical label placement drawing	73
7.7	Typical panel control station drawing	74
8.0	APPENDIX	75
8.1	Operations below 48°F	76
8.2	Water quality control	77
8.3	Inhibited propylene glycol	77
8.4	Pressure-temperature chart for R-22 refrigerant	78
8.5	Chiller capacity and derate chart	79

THIS PAGE INTENTIONALLY BLANK

1.0 GENERAL

- 1.1 INTRODUCTION**
- 1.2 WARNING LABELS**
- 1.3 EFFICIENCY**
- 1.4 SAFETY**
- 1.5 CLEAN AIR ACT**
- 1.6 MISCELLANEOUS**
- 1.6 ABOUT THE OACS CHILLER**
- 1.8 EXAMINE FOR SHIPMENT DAMAGE**
- 1.9 PREPARING UNIT FOR OPERATIONS**



1.1 INTRODUCTION

- A. This manual covers OACS central chillers, all capacities.
- B. When calling for assistance from the Manufacturer's Service Department, it is important to know the model and serial number of the particular unit. The model number encodes critical unit information which is helpful in any attempt to troubleshoot operating difficulties. The serial number allows the service team to locate manufacturing and testing records which can have additional information relating to a particular unit.

1.2 WARNING LABELS

- A. Observe all warning and safety placards applied to the chiller.
- B. Failure to observe warnings can result in serious injury or death.

1.3 EFFICIENCY

- A. Long term efficiency of operation is largely determined by proper maintenance of the mechanical parts of the unit and the water quality.
- B. The Manufacturer recommends filtering where required to prevent solids from plugging critical parts (pumps, heaters, seals for example).
- C. The Manufacturer highly recommends the services of a competent water treatment specialist be obtained and his recommendations followed.
- D. The Manufacturer accepts no responsibility for inefficient operation, or damage caused by foreign materials or failure to use adequate water treatment.

1.4 SAFETY

- A. It is important to become thoroughly familiar with this manual and the operating characteristics of the unit.
- B. It is the owner's responsibility to assure proper operator training, installation, operation, and maintenance of the unit.
- C. Observe all warning and safety placards applied to the chiller. Failure to observe all warnings can result in serious injury or death to the operator and severe mechanical damage to the unit.

1.5 CLEAN AIR ACT

- A. The unit contains HCFC-22 (chlorodifluoromethane). This is a class 2 substance.
- B. Effective July 1, 1992, it is unlawful for any person in the course of maintaining, servicing, repairing, or disposing of refrigeration equipment to knowingly vent or otherwise dispose of any class 2 substance used as a refrigerant in the manner which permits such substance to enter the atmosphere.
- C. De minimis releases associated with good faith attempts to recapture, reclaim or recycle such substance shall not be subject to the prohibition set forth in the preceding paragraph.

1.6 MISCELLANEOUS

- A. The unit is designed to circulate temperature stabilized fluid through the process resulting in process temperature control.
- B. The ability of the unit to maintain process temperature control is significantly affected by the method of installation as outline in section 2 of this manual.
- C. If the operator has any questions concerning the location and operation of the unit, contact the The Manufacturer's Service Department.

1.7 ABOUT THE OACS CHILLER

- A. The unit is designed to operate with fluid temperatures in the 20°F to 70°F range. To operate below 48°F requires the addition of inhibited propylene glycol and modification of the safety control settings. Diligent monitoring of the water/glycol mixture is mandatory to prevent freeze-up of the evaporator. This could cause the evaporator to rupture, allowing water and freon to mix which could cause major damage to the entire refrigeration system.
- B. To operate with fluid temperatures above 70°F requires the addition of a crankcase pressure regulating valve (CPR valve) to the refrigeration system. This is to prevent overloading of the compressor which could cause premature failure. Contact your local refrigeration contractor or the service department for further information.
- C. The refrigeration circuit utilizes a heigh pressure refrigerant and contains several limit control devices for safe and proper operation.
- D. In the 'at-rest' condition, the refrigerant circuit is still under pressure and in most cases, it should be serviced only by a qualified refrigeration technician.

1.8 EXAMINE FOR SHIPMENT DAMAGE

- A. When the unit is delivered, make an immediate inspection for shipment damage, in the presence of the driver if possible. Look for damage to the electrical cabinet, machine crating, or frame. Rough handling in shipment can cause refrigerant leaks or changes in control settings. Check refrigeration gauges for pressure.
- B. If any damage is found, a notation should be made on the delivery receipt before you sign. A claim must be filed with the transportation company. It is their responsibility to pay for shipment damages.

1.9 PREPARING UNIT FOR OPERATION

- A. Remove crate and skid from the machine. When removing the skid, be careful not to disturb or damage refrigeration lines.
- B. Check the data plate on the electrical cabinet to verify the plant's power supply matches the electrical specifications required by the chiller. Incorrect voltage could void warranty.
- C. Locate the unit such that the control panel and all service access panels are easily reached for maintenance and inspection purposes.

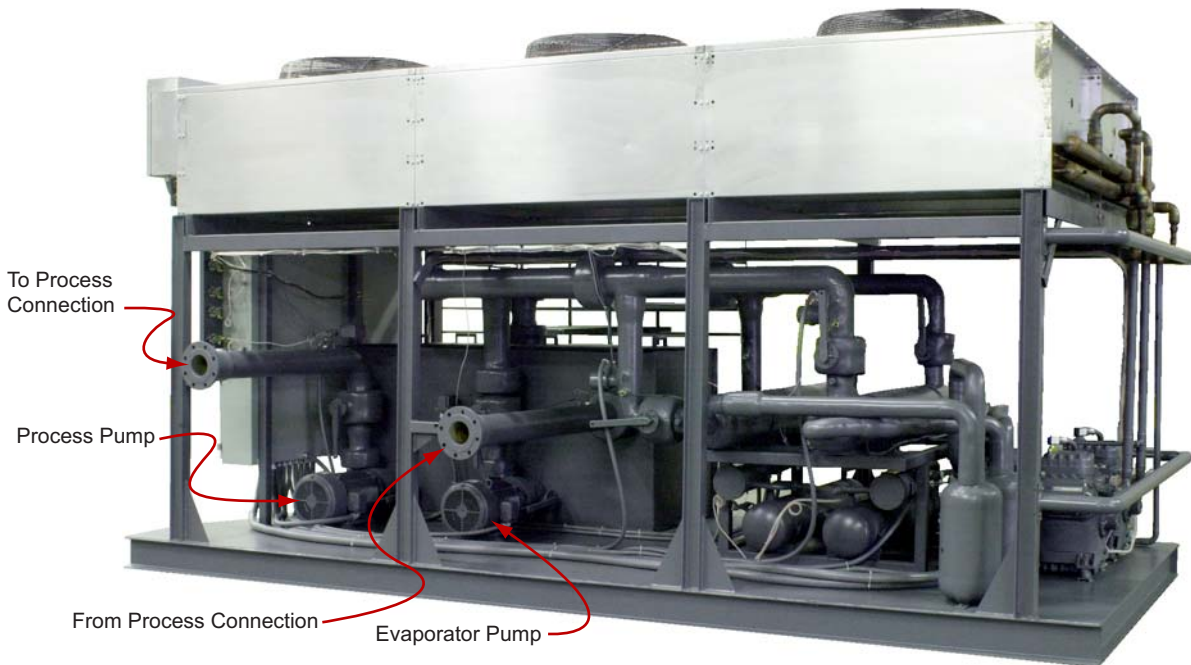
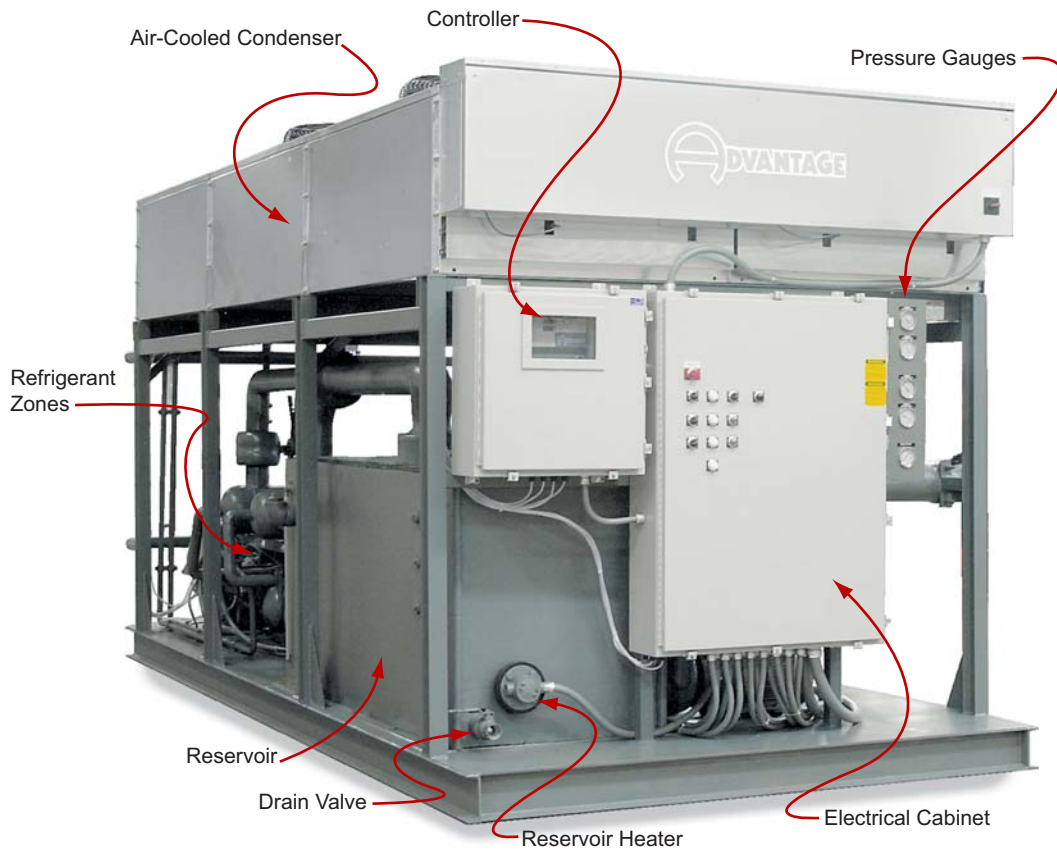

THIS PAGE INTENTIONALLY BLANK

2.0 INSTALLATION

- 2.1 GENERAL**
- 2.2 LOCATION**
- 2.3 TO AND FROM PROCESS CONNECTIONS**
- 2.4 ELECTRICAL CONNECTION**



2.1 GENERAL

- A. All process piping materials (such as hose, rigid piping, valves or filters) used in process water piping circuitry must be rated for 100°F minimum temperature and 100 PSI minimum pressure.
- B. All such materials must have the equivalent or larger diameter of the particular process connection that length of process water piping is connected to.

2.2 LOCATION

- A. All sides of the unit must be a minimum of 4 feet away from any wall or obstruction. Overhead obstructions are not permitted. If enclosed by walls, the unit must be installed as indicated for a unit in a pit.
- B. For installation of multiple units, a minimum of 8 feet is required between units placed side by side. If placed end to end a minimum of 4 feet is required between units.
- C. Units in pits must have the top of the condenser level with or above the top of the pit and a minimum of 8 feet is required between the unit and the pit walls.
- D. Louvers/fences must have a minimum of 80% free area and 4 feet minimum clearance between the unit and the louvers/fence. Height of the louver/fence must not exceed the top of the unit.

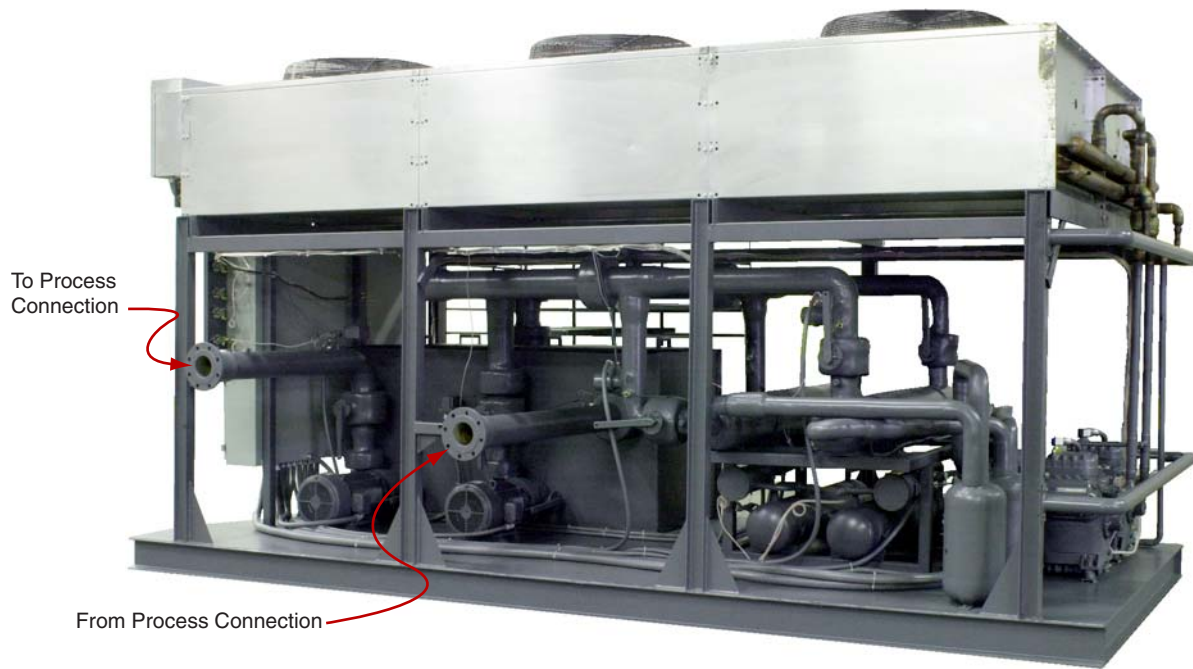

- E. If the chiller is installed in an environment where ambient temperatures could be under 35°F and/or if the unit operating set point will be 48°F or lower, a glycol and water solution must be used instead of water. See section 8.1 for glycol ratio recommendations and proper unit setting.

2.3 TO AND FROM PROCESS CONNECTIONS

- A. Connect the '**TO PROCESS**' to the 'water in' manifold on the mold or process.
- B. Connect the '**FROM PROCESS**' port to the 'water out' port on the process manifold.
- C. Process water piping circuitry should be designed to avoid an excessive use of elbows and/or lengths of pipe or hose. If hose is the material of choice, avoid tight twists or curls and excessive lengths.
- D. Valves and filters may be installed in the process water piping circuitry to facilitate service and maintenance provided that such devices maintain the full inside diameter of the process connection. If installed, all such devices must be open and clean during unit operation.

2.4 ELECTRICAL CONNECTION

A. GENERAL

- 1. Units are constructed with a dust tight electrical enclosure and branch circuit fusing. Electrical power supply requirements are identified on the equipment data plate. Determine the plant's voltage supply is the same as the unit's voltage requirements.

WARNING: Do not connect the unit to a voltage supply source not equal to the unit's voltage requirements as specified on the unit's data plate. Use of incorrect voltage will void the unit's warranty and cause a significant hazard that may result in serious personal injury and unit damage.

- 2. Appropriate conduit and fittings should be selected which will maintain the integrity of the cabinet.
- 3. Supply a power conductor sized according to the unit's power supply requirements. Connect the power conductor to the unit's power supply entry terminal block or the fused disconnect switch. Some models may be supplied with an optional disconnect switch. The owner supplied fused disconnecting means shall be sized and installed according to the unit's power supply requirements and local electrical codes.

C. CONTROL CIRCUIT WIRING

1. The unit's supplied control circuit is 110 volt, 1 phase, 60 cycle. The control circuit is supplied by the factory installed transformer. An inline control circuit fuse is provided.

D. GENERAL

1. Make certain all ground connections to the unit are properly affixed.
2. Make certain power conductor, disconnecting means, and fusing are properly sized according to the unit's power supply requirements.

E. INFORMATION REGARDING 'PHASING' OF SCROLL COMPRESSORS

1. All portable chillers that have pumps, the compressor(s) will be set in phase with the pump during the testing process at the factory.
2. After installation the phase status must be checked by observing the pump motor shaft on the end of the pump and comparing its rotation to the directional arrow on the motor. In either case, if the phase needs to be altered, it should be done at the main power entry.

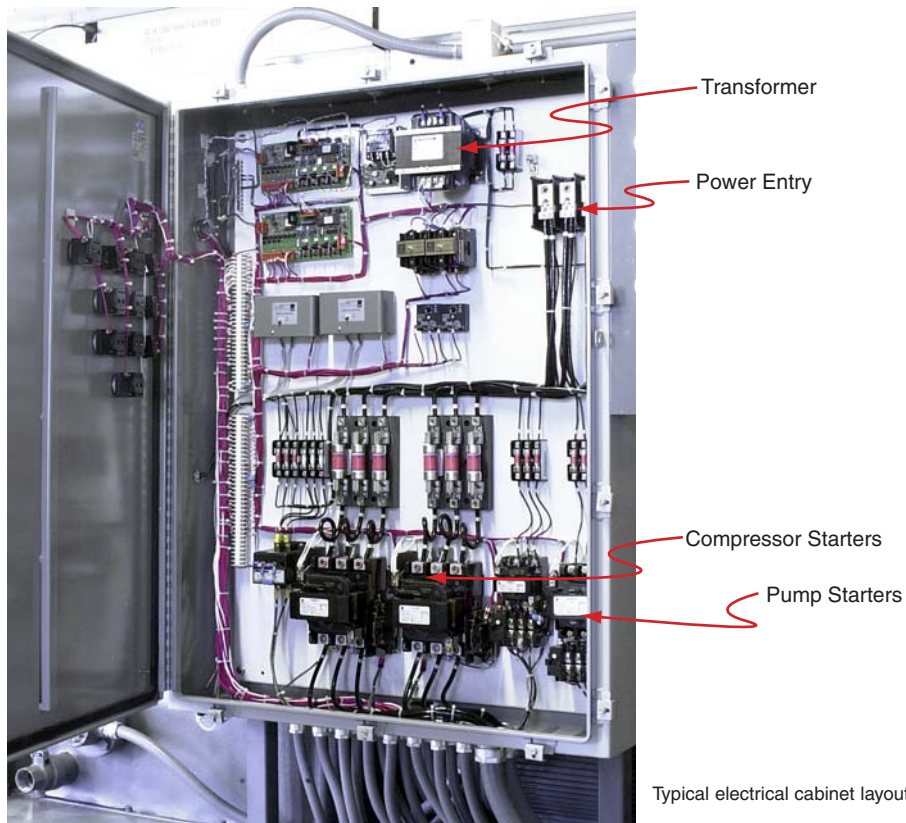

Typical electrical cabinet layout.

3.0 OPERATIONS

- 3.1** GENERAL
- 3.2** START UP/OPERATIONS PROCEDURE
- 3.3** INSTRUMENT OPERATION : M1 CONTROLLER
- 3.4** INSTRUMENT OPERATION : MK LE CONTROLLER
- 3.5** INSTRUMENT OPERATION : MULTIZONE CONTROLLER
- 3.6** SHUT DOWN



3.1 GENERAL

- A. Failure to follow the factory required operations procedure may adversely affect the unit's ability to adequately control process temperature and may create a hazardous operating condition which may result in serious operator injury and/or unit damage.

- B. **IMPORTANT.** If this unit contains a hermetic or semi-hermetic reciprocating compressor it is equipped with a crankcase heater on the compressor. While the compressor is idle, the crankcase heater prevents freon vapor from migrating to and condensing in the compressor crankcase. If freon is allowed to condense in the crankcase, it can be drawn into the cylinders upon start up. This can cause catastrophic damage to the connecting rods, pistons, and valve plates.

To avoid this, **BEFORE THE UNIT IS STARTED, THE POWER SUPPLY SHOULD BE APPLIED TO THE UNIT FOR AT LEAST 12 HOURS, OR UNTIL THE BOTTOM OF THE COMPRESSOR IS WARM TO THE TOUCH.**

If the power has been disconnected more than two hours, the power should be applied for six hours before restarting. Power should be applied to the unit continuously, except for service purposes. The crankcase heater should be checked for proper operation on a regular basis.

UNITS WITH SCROLL COMPRESSORS DO NOT HAVE A CRANKCASE HEATER AND THIS PROCEDURE IS NOT NECESSARY.

- C. The OPERATIONS segment of this manual is divided into the following sections:
 - 3.2 **Start up/operations** - follow this segment to start the unit after the initial install to the process system or to restart the unit after reinstallation to the same or different process system. This section includes information on system fill, electric motor phasing (pump rotation) and process flow adjustments.
 - 3.3 **M1 Controller** - follow this segment to start up and operate the M1 chiller control.
 - 3.4 **MKLE Controller** - follow this segment to start up and operate the MKLE chiller control.
 - 3.5 **Multizone Controller** - follow this segment to start up and operate the Multizone MZ3 chiller control. This section includes information on setpoint selection and adjustment, and feature explanations.

- 3.4 **Shut down procedure** - follow this segment to shut down the unit. This segment includes information on system shut down, electrical power supply precautions, and disconnection from system.

3.2 START UP / OPERATION PROCEDURE

A. SYSTEM FILL

1. The unit has an internal reservoir which must be filled and maintained for proper operation. The unit has a level switch mounted at the proper water level in the reservoir.
2. **WATER QUALITY CONTROL.** Lack of, as well as, improper water treatment can damage the chilling unit. The services of competent water treatment specialist should be obtained and their recommendations followed. It is the equipment owner's responsibility to prevent damage from foreign material or inadequate water treatment. See water treatment section in **section 8** of this manual for more information.
3. **MANUAL FILL.** Disconnect the electrical power supply and access the reservoir. Add fluid directly to the reservoir. When the pump is first started, as process lines are filled and air is purged, additional fluid may be required to restore the reservoir to the correct level. Verify reservoir level via the coolant sight glass.

B. ELECTRIC MOTOR PHASING (PUMP ROTATION)

1. The operator must determine the unit is phased correctly by visually inspecting the rotation of the pump motor shaft. The procedure is outlined below. Incorrect phasing results in poor operation and eventual damage to the unit.
 - a. Supply electrical power to the unit. Once the correct voltage is supplied to the unit, the POWER switch on the unit's control panel will illuminate. Adjust the setpoint to 70°F to prevent the compressor from activating during this procedure.
 - b. Remove all necessary cover panels to access the pump motor. **Note that the electrical power is engaged at this point and caution must be observed while the electrical supply is engaged and cabinet panels are removed and opened.**
 - c. Locate the electric motor. The electric motor can be identified when the electrical panel cover is open. The operator must identify the motor shaft inside

the electric motor housing. The motor shaft can be seen through the vent slots in the motor housing or by removing the shaft cover.

- d. Toggle the illuminated ON/OFF SWITCH. This will quickly cycle the pump motor “on” and then “off”.
- e. Observe the motor shaft. When the ON/OFF SWITCH is on, the motor shaft will rotate. When switched off, the shaft will slowly “coast” to a stop. As the shaft slows, the operator can identify the rotation of the motor shaft. Correct rotation (correct phase) is “clockwise”, when viewed from the rear of the motor. Incorrect rotation is “counter-clockwise” (incorrect phase) when viewed from the rear of the motor. If the shaft does not rotate when the ON/OFF SWITCH is on, the operator must identify the cause as outlined in the troubleshooting and repair section of this manual.
- f. If the motor shaft is phased correctly (shaft turns in a clockwise direction), continue with **step C**. If the motor shaft is **NOT** phased correctly (shaft turns in a counter-clockwise direction), correct as outlined in **step 2**.

2. If the unit is phased **incorrectly**, the operator must:

- a. Disengage the electrical power supply to the unit at the unit’s disconnect switch. Follow proper lockout procedures before proceeding.
- b. Once the electrical power supply is disengaged, reverse any two power leads of the power cord at the disconnect terminals.
- c. **Note:** Changing any two power leads of the power cord will correctly phase the power supply to the unit. **The operator must reverse the power leads at the disconnect switch only and not at the power entry terminals on the unit’s electrical panel.** The unit’s internal electrical system wiring is phased correctly at the factory and must not be altered in the field.

C. ADJUSTMENT OF CENTRIFUGAL PUMP FLOW

1. When starting a piece of equipment with a centrifugal pump, it is important to properly set the flow rate to prevent overloading of the electric motor. The following is the start up procedure for a typical two pump system.



2. Fully open the suction valves to the pumps allowing the pump case to fill with water. Never allow the pump to operate dry as this can cause shaft seal failure.
3. Close the discharge valves. A centrifugal pump can be operated with no flow without damage, although this should not be for an extended period of time. Internal friction will cause the water in the pump case to overheat.
4. Place an amp meter on one leg of the process pump leads at the motor starter block and start the motor. Slowly open the discharge valve allowing the process piping to fill with water. After flow is established, continue to open the discharge valve. The amp draw will increase as the flow increases until you reach the run load amp rating on the motor data tag.
5. **Please note.** On initial start up, the water use points may not be sufficient to fully load the motor. As you add use points, you should recheck the amp draw on the motor and adjust the discharge valve as needed to prevent overloading the motor.
6. Never operate a pump without water in the case or never operate a pump without checking for proper amp draw.
7. Always operate the pump with the suction valve fully open. Adjust the amp draw with the discharge valve starting from a closed position. Starting from a wide open position can give a false reading and result in motor failure.
8. If during operations the motor overload trips, the overloads will need to be manually reset to restart operations. Once the pump is restarted, check for excessive motor amps at the motor starter block and throttle back the pump's discharge valve as required.

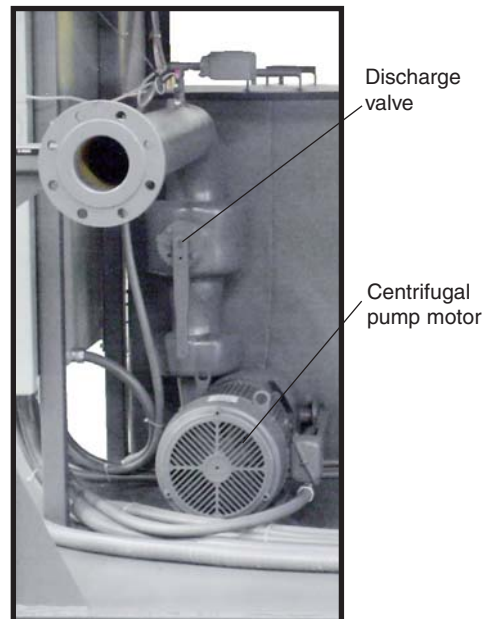

3.3 INSTRUMENT OPERATION - M1 CONTROLLER

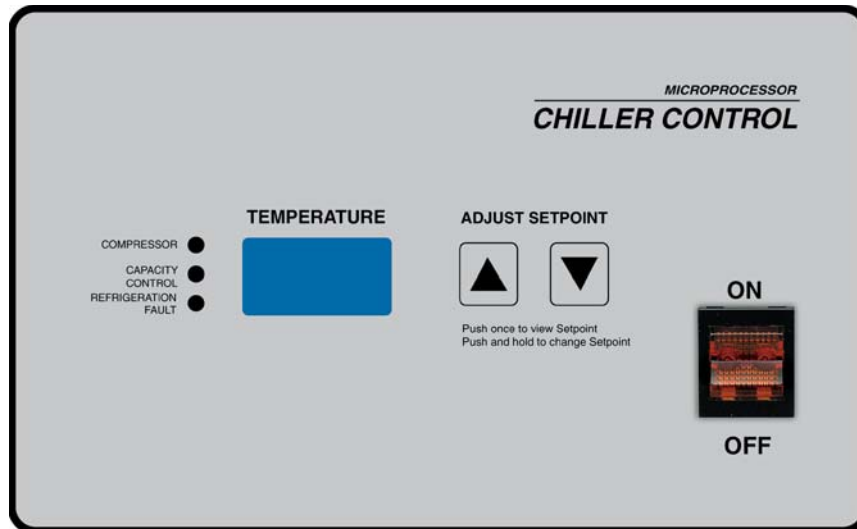

Chiller Control.

Figure 3.3A

A. INSTRUMENT START-UP

1. When the correct electrical power and adequate water supply pressure are supplied to the unit, it is possible to start the unit.
2. Upon power up, the instrument displays “ChF” indicating that the unit is in Fahrenheit temperature mode or “ChC” indicating that it is in Celsius mode. The control then shows the current setpoint for approximately 2 seconds before reverting to the To Process temperature. When power is supplied to the unit, the ON/OFF switch will illuminate.

3. PRECAUTIONS:

The chiller control is programmed from the factory with a setpoint range of 48° to 90°F. To operate below 48°F, the addition of inhibited propylene glycol and modification of the safety control settings are required. Diligent monitoring of the water/glycol solution is mandatory to prevent freezing of the evaporator. Freezing may cause the evaporator to rupture allowing water and freon to mix which will cause major damage to the refrigeration system.

Operating above 70°F requires the addition of a refrigerant crankcase pressure regulating (CPR) valve. The CPR valve is necessary to prevent overloading of the compressor which can cause premature failure.

Contact your local refrigeration contractor or the factory for further information. The operating range of the chiller control

may be changed to 10°F - 90°F by adjusting the Setpoint Lockout (SPL) jumper. Refer to the technical section of this manual for more information.

B. INSTRUMENT OPERATION

1. **To start the unit, toggle on the illuminated ON/OFF SWITCH.** The chiller control will begin temperature control operations.
2. To select setpoint temperature, press and hold the UP ARROW or DOWN ARROW keys until the desired set point temperature is displayed in the TEMPERATURE WINDOW. The default range for the setpoint temperature is 48° - 90°F or 9° - 32°C.
3. The setpoint temperature can be displayed by pressing the UP ARROW or DOWN ARROW keys. The setpoint temperature will be displayed for 5 seconds.
4. When the compressor is turned off, the instrument will wait 3 minutes before turning it back on regardless of the To Process temperature or setpoint. If a fault has occurred, the control will attempt to turn the compressor on after 3 minutes powered down. If the fault condition remains, the control will turn the compressor off and retry after 1 minute. This sequence will repeat until the compressor turns on or instrument power is cycled.
5. Under normal conditions (no fault conditions, compressor has been off for three minutes) the instrument will turn on the compressor when the To Process temperature is above the setpoint.
The instrument will turn on the hot gas bypass when the To Process temperature is below the setpoint by no more than 3 degrees.

The instrument will turn off the compressor and hot gas bypass when the To Process temperature is 4 degrees or more below the setpoint.

C. INSTRUMENT CONTROLS

1. **ILLUMINATED ON/OFF SWITCH:** This rocker switch starts or stops the unit. Electrical power is supplied to the unit when the switch is illuminated.
2. **UP ARROW and DOWN ARROW KEYS:** Depress and hold this push button to increase (UP ARROW) or decrease (DOWN ARROW) the setpoint temperature. If the push button is pressed momentarily the setpoint value is incremented or decremented by one degree. If the push

button is held down the setpoint will increase or decrease continuously.

3. **SETPOINT LOCK OUT JUMPER:** This jumper controls whether the user is allowed to reduce the setpoint below 48°F or 9°C. If the jumper is in position 1 (farthest from the SPL label) the user IS NOT ALLOWED to reduce the setpoint below 48°F or 9°C. If the jumper is in position 2 (closest to the SPL label) the user is allowed to reduce the setpoint to 10°F or -11°C.

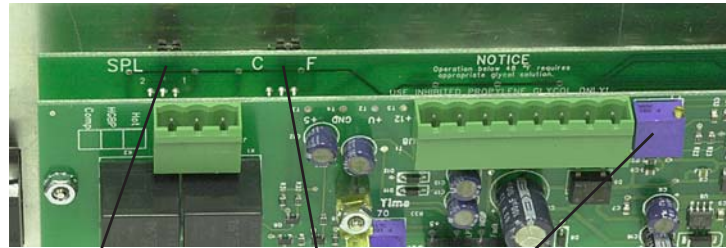

Figure 3.3B
Setpoint Lock Out Jumper Temperature Display Jumper Probe Calibration

4. **TEMPERATURE DISPLAY JUMPER:** if this jumper is in the “F” position, the To Process and Setpoint temperatures are displayed in Fahrenheit. If the jumper is in the “C” position, the To Process and Setpoint temperatures are displayed in Celsius.
5. **Probe Calibration:** This pot (CALPOT 1) is used to calibrate the probe circuit.

D. STATUS LIGHTS

1. **COMPRESSOR:** Illuminates when compressor is turned on.
2. **CAPACITY CONTROL:** Illuminates when capacity control system is turned on.
3. **REFRIGERANT FAULT:** Illuminates when there is a high pressure or low pressure alarm. Check troubleshooting section of this manual for more details.

High Pressure Alarm. If the chiller control detects a high pressure condition it will immediately turn off the compressor and hot gas bypass.

Low Pressure Alarm. After the compressor is turned on, the control has a 15 second buffer for the low pressure alarm. If a low pressure condition occurs within the first 15 seconds, the control waits the amount of time specified by the “LP TIME” potentiometer before indicating an alarm and turning off the compressor. If the condition is corrected

before the time expires, no alarm occurs. If a low pressure condition occurs 15 seconds after the compressor turns on, the instrument waits 20 seconds before indicating an alarm and turning off the compressor.

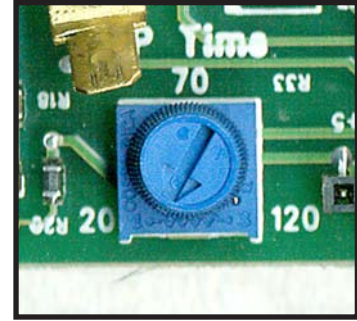

Low Pressure Potentiometer. Figure 3.3C

E. TEMPERATURE DISPLAY

1. A three digit display window indicates the appropriate temperature. The window also displays the numeric value for the setpoint temperature.
2. The To Process temperature is always displayed unless a button has been pressed. If there is a probe error, the display will show three dashes “---”.

F. PRESSURE GAUGES

1. **PROCESS PRESSURE GAUGE:** Indicates process pump pressure.
2. **REFRIGERANT HEAD PRESSURE GAUGE:** Indicates refrigerant pressure on the discharge side of the compressor. The refrigerant head pressure is also the condensing pressure which is critical to equipment efficiency. Head pressure on water condensed units will vary with ambient temperatures between 190-290 psig.
3. **LOW PRESSURE GAUGE:** Indicates refrigerant pressure on the suction side of the compressor. This pressure will fluctuate with the process temperature.

3.4 INSTRUMENT OPERATION : MAXIMUM LE

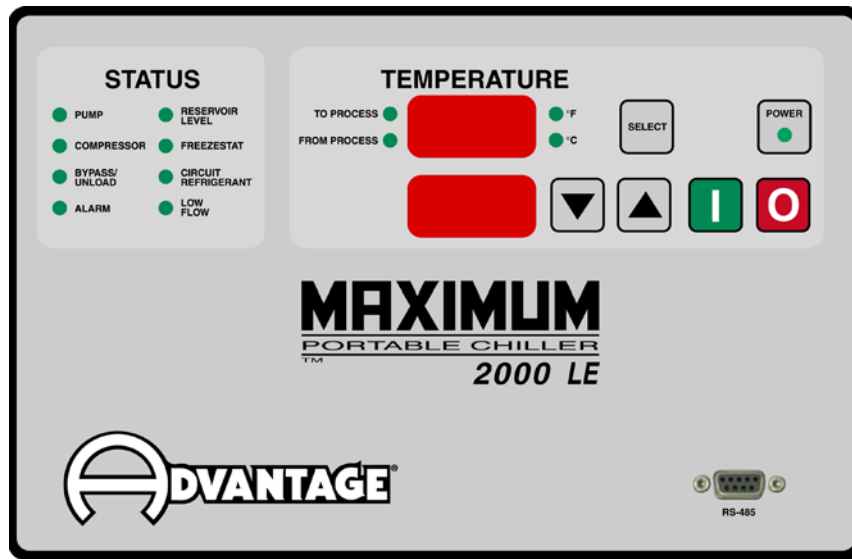

LE instrument display

Figure 3.4A

A. INSTRUMENT START-UP

1. When the correct electrical power and adequate water supply pressure are supplied to the unit, it is possible to start the unit for temperature control duty.
2. When the electrical power supply is supplied to the unit, the instrument (figure 3.4A) will momentarily illuminate all indicating lights and digits on the display head. After a short delay, the instrument will display the software version number. At this time, the operator can verify that all lights and digits are functioning properly. If the operator determines an indicating light or digit does not illuminate, the instrument must be removed and sent to the factory for repair.
3. With electrical power supplied to the unit, the POWER light will illuminate. The display will remain dark with exception of the RESERVOIR LEVEL light which will be 'solid green' if this condition is 'ok'. The FLOW light will 'flash red' to indicate that the pump is not on (not generating flow). This is the normal "stop" state of the instrument. If the operator determines the RESERVOIR LEVEL light is 'flashing red', the operator must determine the reason and correct:
 - a. **Water level:** When the reservoir water level is below the level switch mount, the automatic water make-up system is activated in an effort to restore the reservoir to the proper operating level.

- d. **Low pressure switch open:** An “L-P” in the temperature display window indicates the low pressure safety switch is open. Chiller operations stop when the refrigerant suction pressure drops below 58 PSI. While the compressor is inactive, the pressure normally builds back up to the cut-in pressure of 63 PSI, at which point the low pressure safety switch automatically resets, and a 3 minute time delay cycle begins (to prevent compressor short-cycling). If the low pressure safety switch does not reset, operations are prevented. Contact the service department for further instructions.

 - e. **Low oil pressure switch open:** A ‘flashing red’ CIRCUIT REFRIGERANT light indicates the oil pressure safety switch is open. The oil pressure safety switch is found on 15 to 30 ton semi-hermetic compressors. Normally, the switch will open if there is insufficient oil in the compressor crankcase or due to lack of sufficient compressor warm up before operations start. This switch must be manually reset before operations can continue.
-
- 6. Press the START push button to activate the coolant circuit. If the existing coolant temperature is above the currently selected setpoint temperature, the refrigerant circuit will activate. The operator can stop process operations (refrigerant and coolant circuits) by pressing the STOP push button.

 - 7. To select the operating setpoint, use the SELECT key to index through the temperature functions until the ‘SP’ is displayed in the top window. The current setpoint temperature is displayed in the bottom window. Use the UP and DOWN ARROW keys to change the setpoint temperature.

 - 8. **PRECAUTIONS:** The instrument is programmed from the factory with a setpoint range of 48° to 70°F. To operate below 48°F, the addition of inhibited propylene glycol and modification of the safety control settings are required. Diligent monitoring of the water/glycol solution is mandatory to prevent freezing of the evaporator. Freezing may cause the evaporator to rupture allowing water and freon to mix which will cause major damage to the refrigeration system. Operating above 70°F requires the addition of a refrigerant crankcase pressure regulating (CPR) valve. The CPR valve is necessary to prevent overloading of the compressor which can cause premature failure. Contact your local refrigeration contractor or the factory for further information. The operating range of the instrument may be changed to 20°F - 90°F by adjustment of the CPU DIP switch. Refer to

the technical section of this manual for more information. The instrument is set up from the factory to give an alarm light and a 115 volt alarm output if the temperature to process deviates more than 10° from the setpoint.

9. After selecting the setpoint temperature, the operator may leave the display in the SET POINT state. The display will automatically return to the TO PROCESS temperature state after thirty seconds. If the operator leaves the display in any state other than the TO PROCESS state, the display will automatically revert after 30 seconds of inactivity.
10. The setpoint temperature is continuously displayed in the lower window for quick comparison to actual process temperature.
11. The operator can stop operations by pressing the STOP push button. This will disengage the refrigerant and coolant circuits.

B. INSTRUMENT OPERATION

1. When the START push button switch is pressed on, the instrument will begin temperature control operations and the 'to process' temperature will begin to drop.

2. When the 'to process' temperature drops 1° below the setpoint, the instrument will activate the capacity control system to match the cooling capacity to the present load, as indicated by the BYPASS/UNLOAD light (figure 3.4B).

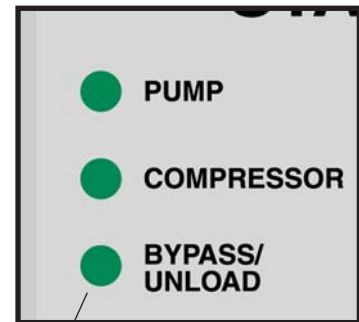

Bypass / Unload light on LE instruments Figure 3.4B

3. If the load is less than the minimum capacity of the chiller, the 'to process' temperature will continue to drop. At 3° below setpoint the compressor will stop and enter a 3 minute time delay period before restarting at 1° above setpoint. The time delay is to prevent short cycling damage to the compressor.

C. INSTRUMENT CONTROLS (figure 3.4C)

1. **START:** (green color button) this push button engages/disengages electrical supply to the coolant pump and refrigerant compressor. Please note that the refrigerant compressor will not start unless the coolant pump is operating.

2. **STOP:** (red color button) this push button disengages electrical supply to the coolant pump and refrigerant compressor.
3. **SELECT:** Depress to index through the “to”, “from” and “set point” temperatures.
4. **UP ARROW:** Depress and hold this push button to increase the setpoint temperature. If this push button is pressed momentarily the setpoint value is incremented by one degree. If the push button is held down for more than one second, the setpoint will increase slowly at first and then faster after about two seconds.
5. **DOWN ARROW:** Depress and hold this push button to decrease the setpoint temperature. If this push button is pressed momentarily the setpoint value is incremented by one degree. If the push button is held down for more than one second, the setpoint will increase slowly at first and then faster after about two seconds.
6. **POWER LIGHT:** Illuminates when the proper supply of electrical power is applied to the unit.

D. TEMPERATURE DISPLAY (figure 3.4C)

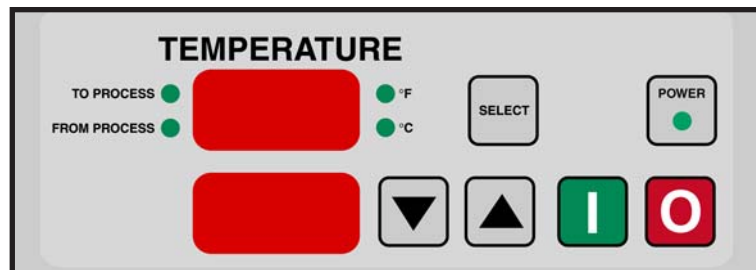

Figure 3.3C

1. The upper three digit display window indicates the appropriate temperature either in **Fahrenheit** or **Celsius** (as selected). The lower window also displays the numeric value for the setpoint temperature. A ‘solid red’ TO or FROM light will illuminate beside the parameter currently being displayed.
2. The instrument is programmed at the factory to indicate temperature in Fahrenheit. The instrument can be programmed to display temperature in Celsius by changing the orientation of the DIP switch. Refer to the technical section of this manual for more information.
3. **TO PROCESS:** Indicates liquid temperature being delivered from the chiller.

4. **FROM PROCESS:** Indicates liquid temperature returning to the chiller.
5. **°F:** indicates temperature is displayed in Fahrenheit temperature scale.
6. **°C:** indicates temperature is displayed in Celsius temperature scale.

E. STATUS DISPLAY (figures 3.4D)

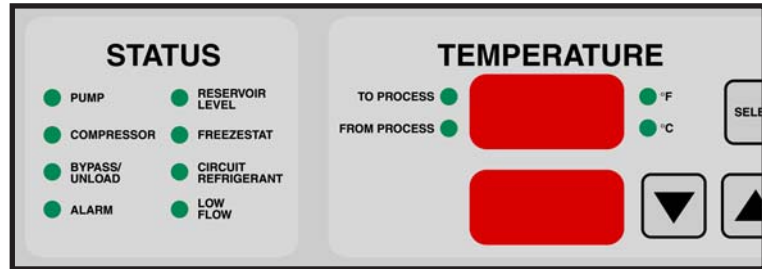

Figure 3.4D

1. **PUMP:** Illuminates 'solid red' when the coolant pump is operating. The PUMP light will remain dark if the pump is not operating.
2. **COMPRESSOR:** Illuminates 'solid red' when the instrument engages the compressor contactor. Engaging the compressor contactor supplies electrical current to the compressor. If the compressor is unable to operate, the light will remain dark.
3. **BYPASS/UNLOAD:** Illuminates 'solid red' when the instrument has engaged the capacity control system.
4. **ALARM:** Illuminates 'solid red' when the "to process" temperature has deviated +/- 10° from setpoint. Note: The temperature deviation alarm circuit is only activated after the chiller has cooled the circulating fluid to the setpoint one time.
5. **RESERVOIR LEVEL:** Illuminates 'flashing red' when the process water level has dropped below the safe operating level, at which time the automatic water make-up system activates to restore the reservoir to the correct level. When the reservoir level is 'ok', the light will remain dark.
6. **FREEZESTAT:** Illuminates 'flashing red' when the evaporator out temperature has reached the minimum safe operating temperature (normally 40°F) at which time the compressor will shut down to avoid water freezing. When

the water temperature is above the freezestat setting, the light will remain dark.

7. **CIRCUIT REFRIGERANT:** Illuminates when a refrigerant safety switch (high pressure safety, low pressure safety or oil pressure safety) has opened preventing the compressor from operating until the condition is resolved. When the refrigerant circuit safety switch are 'ok', the light will remain dark.
8. **LOW FLOW:** Illuminates 'flashing red' when the process fluid flow is below the minimum safe operating rate. When the flow is above the safe operating rate, the light will be dark. When the flow rate is 'ok', the light will remain dark.
9. **L-P LOW REFRIGERANT PRESSURE:** When the refrigerant low pressure drops below 58PSI the compressor will stop and an "L-P" will be displayed in the temperature window. See troubleshooting section for more information.

3.5 INSTRUMENT OPERATION : MULTIZONE CONTROLLER

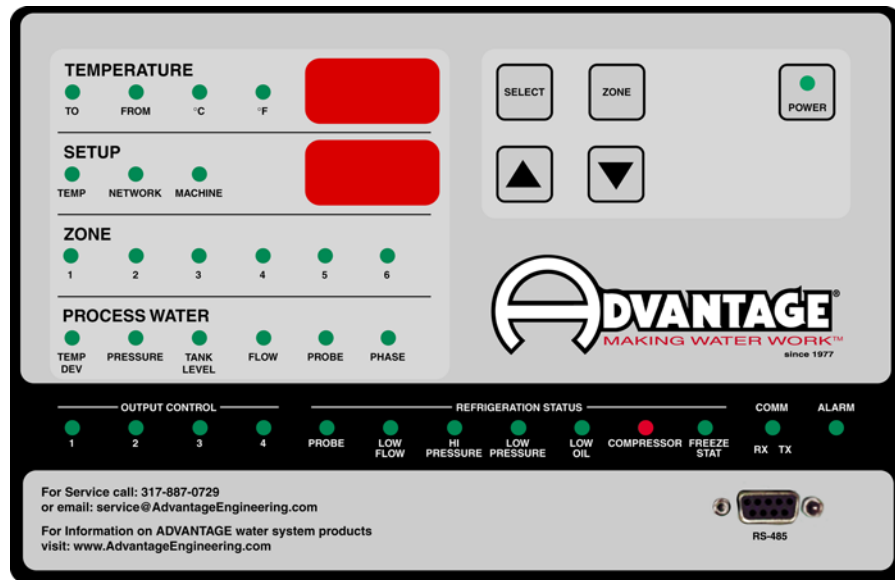

Multizone Instrument display

A. GENERAL

1. The operator interface is mounted (in most cases) on the electrical cabinet door.
2. The MZC (multi-zone controller) instrument is mounted inside the electrical cabinet. The MZC controller and its operation are detailed in section 3.13.
3. This section covers the operation of the operator control panel.

B. TEMPERATURE DISPLAY

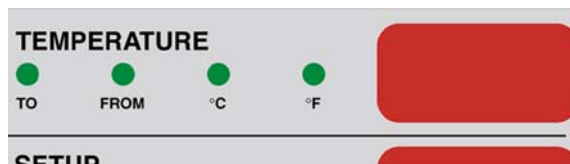

1. Temperature information is displayed via the three digit display window.
2. **TO:** illuminates when the TO PROCESS water temperature is displayed. This is the default setting of the TEMPERATURE DISPLAY window.
3. **FROM:** Illuminates when the FROM PROCESS water temperature is selected.

NOTE: The instrument will revert back to the TO PROCESS temperature display after 10 seconds if the SELECT key is used to move from the TO PROCESS display.

NOTE: Both TO and FROM lights are on when zone EVA IN and EVA OUT temperatures are displayed.

- D. °C: Illuminates when the °C (Celsius) temperature display parameter is selected.
- E. °F: Illuminates when the ° F (Fahrenheit) temperature display parameter is selected. °F is the default setting of the instrument.

C. SETUP DISPLAY

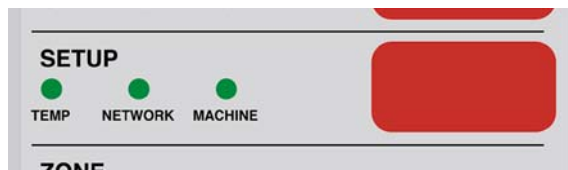

1. When the **SELECT** key is pressed, and the unit is NOT in zone display the display will cycle forward through all available temperature and setup parameters.

The currently selected setup parameter is indicated in the TEMPERATURE display window (i.e. “Hi” for High Deviation, “Lo” for Low Deviation) and the value is displayed in the SETUP display window. Values are changed with the Up and Down arrows. The available parameters are listed below.

2. **Temperature/Setup display sequence:**

STANDARD DISPLAY MODE:

TEMPERATURE DISPLAY	SETPOINT DISPLAY
------------------------	---------------------

- | | |
|-------|--|
| To | Setpoint |
| From | Setpoint |
| ‘SP’ | Setpoint |
| ‘LE’ | Lead compressor |
| ‘HI’ | High temperature deviation limit |
| ‘Lo’ | Low temperature deviation limit |
| ‘Pro’ | Protocol selection (SPI/CAC) |
| ‘Adr’ | Protocol address selection (1-99 / 0-9) |
| ‘RA†’ | Protocol baud rate selection (1200-9600) |
| ‘Unt’ | Temperature units selection (°F/°C) |

C. TEMP: illuminates when the following parameters are selected:

- TO:** To process temperature
- FROM:** From process temperature
- SP:** Setpoint temperature
- HI:** High temperature deviation limit
- Lo:** Low temperature deviation limit

1. When the instrument is in the TO, FROM or SP temperature display, the operator may adjust the setpoint temperature with the UP/DOWN arrow keys.
2. **SP:** programs the process setpoint. It can be set to a range of 70° - 48° or 90° - 10° depending on the state of SW-1, referenced in the switch description section.
3. **HI:** programs the high alarm temperature deviation limit. This is the high temperature setting at which an alarm is activated if the 'to process' temperature reaches it. 1-30 units selectable.
4. **Lo:** programs the low alarm temperature deviation limit. This is the low temperature setting at which an alarm is activated if the 'to process' temperature decreases to it. 1-30 units selectable.

D. NETWORK: illuminates when the following parameters are selected:

- Pro:** protocol selection
- Adr:** protocol address selection
- rAt:** protocol baud rate selection

1. **Pro:** sets the protocol selection. The protocol is the data format for communications between the unit and the host computer. SPI (standard Society of Plastics Industry) or CAC (standard used on older CMI machines) protocols selectable.
2. **Adr:** sets the communication address. This is the number assigned to the unit in a network. 1-99 units selectable in SPI protocol and 0 - 9 in CAMAC protocol.
3. **rAt:** programs the baud rate. The baud rate is the data transfer rate between the unit and the host computer. 1200, 2400, 4800, 9600 units selectable.

E. MACHINE: illuminates when the following parameters are selected:

- Unt:** temperature unit selection
- Prb:** from process probe calibration.

1. **Unt:** sets temperature display. Select 'F' for Fahrenheit temperature display or select 'C' for Celsius temperature display.
2. **Prb:** contact factory for details.

F. ZONE DISPLAY



1. The LED's in this section indicate which ZONE is selected for viewing. The status for the selected Zone is displayed in the 'OUTPUT CONTROL' and 'REFRIGERATION STATUS' sections.
2. The operator can select which zone is displayed by using the **ZONE** button. An ON or FLASHING LED indicates the selected zone.

G. PROCESS WATER DISPLAY



1. **TEMP DEV:** illuminates according to the current state of temperature deviation:
 - a. **SOLID GREEN:** when the process temperature is within the programmed parameters.
 - b. **YELLOW:** if the SETPOINT or TO PROCESS temperature different is greater than the programmed HI/LO deviation settings.
 - c. **FLASHING RED:** after about 90 seconds in the YELLOW condition, the LED will display FLASHING RED and the alarm will be sounded. If the difference returns to within acceptable limits before the 90 seconds has elapsed, then the LED will return to GREEN.
2. **PRESSURE:** illuminates according to the current state of process pressure:

- a. **SOLID GREEN:** the process pressure is within the programmed parameters.
 - b. **FLASHING RED:** the process pressure has deviated out of the programmed parameters.
 - c. **SOLID RED:** the process pressure had once deviated out of the programmed parameters but is now within the programmed parameters.
3. **TANK LEVEL:** illuminates according to the current state of tank level:
- a. **SOLID GREEN:** the reservoir tank is at proper operating level.
 - b. **FLASHING RED:** the reservoir level has dropped below the proper operating level and the make-up supply system is activated to restore the water level
 - c. **SOLID RED:** the proper operating level has been restored.
4. **FLOW:** Does not display flow status at this time.
5. **PROBE:** illuminates according to the current state of the process and zone probes:
- a. **SOLID GREEN:** the process probes are ok and working fine.
 - b. **FLASHING RED:** one of the process probes is not functioning correctly.
 - c. **SOLID RED:** one of the probes had a fault, but the fault is no longer present.
6. **PHASE:** illuminates according to the current state of electrical phase:
- a. **SOLID GREEN:** the electrical phase is within the acceptable parameters.
 - b. **FLASHING RED:** indicates improper phasing of the incoming 3 phase supply.
 - c. **SOLID RED:** the phasing had once been 'in fault' but is now restored.

H. OUTPUT CONTROL SECTION

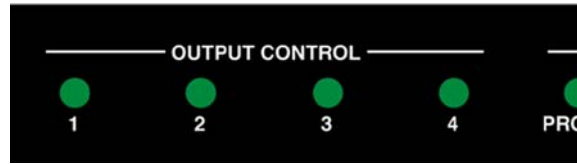

1. The following LED's are SOLID GREEN when the output is "ON".
2. **COMPRESSOR:** illuminates when the compressor has cycled on.
3. **CAPACITY 1:** illuminates when the controller has cycled on the first stage of capacity control, either a hot gas bypass system or a cylinder unloading system, depending on the configuration.
4. **CAPACITY 2:** illuminates when the controller has cycled on the second stage of capacity control. May not be available, depending on capacity control configuration.
5. **CAPACITY 3:** illuminates when the controller has cycled on the third stage of capacity control. May not be available, depending on capacity control configuration.

I. REFRIGERATION STATUS SECTION

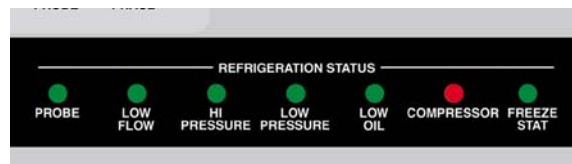

1. Machine status lights indicate the operating status of several machine components, PER ZONE. Further operational and troubleshooting information for each component is located elsewhere in this manual. For each component:
 - a. **SOLID GREEN:** indicates the component is currently at an acceptable run condition.
 - b. **FLASHING RED:** indicates the component is currently at an unacceptable run condition.
 - c. **SOLID RED:** indicates the component had once been at an unacceptable run condition, but is now at an acceptable run condition. A solid red light can be changed into a solid green light by pressing the 'select' key.

2. **PROBE:** indicates the status of the zone evaporator temperature probes.
3. **LOW FLOW:** indicates the status of the zone 'low flow' switch.
4. **HI PRESSURE:** indicates the status of the refrigerant 'high pressure' safety switch.
5. **LOW PRESSURE:** indicates the status of the refrigerant 'low pressure' safety switch.
6. **LOW OIL:** indicates the status of the 'low oil' pressure safety switch. This light activates on models with a 15-30 ton semi-hermetic compressor.
7. **COMPRESSOR:** indicates the status of the zone compressor motor overload relay.
8. **FREEZESTAT:** indicates the status of the 'freezestat' safety switch.

J. COMMUNICATION STATUS

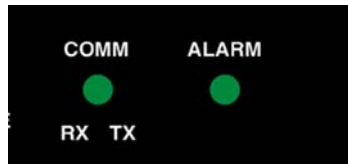

1. The communication display indicates the type of (SPI/CAC) exchange between the host computer and the controller.
 - a. **FLASHING GREEN:** indicates the controller is sending information to the host computer.
 - b. **FLASHING YELLOW:** indicates the host computer is sending information to the controller.

K. ALARM status

1. When this light illuminates RED, an unacceptable condition has developed, at which time a 115 volt alarm output is generated for an external (factory or customer installed) alarm beacon or buzzer.
2. Pressing the SELECT or ZONE key can silence the visual and/or audible alarm signal.

L. OPERATOR CONTROLS

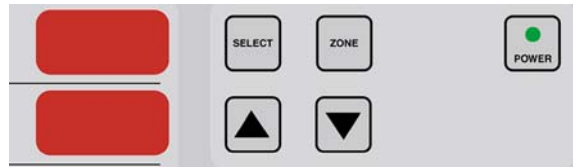

1. **SELECT:** depress this button to index through the 'system/zone' temperature and 'system/zone' parameters.
2. **ZONE:** depress the button to index through the available refrigerant zone displays. When in the 'zone mode' the zone display LED's will flash. If the SELECT button is pressed while in a zone LED is flashing, the zone parameters will be displayed. Zone parameter sequence.

TEMPERATURE DISPLAY SETPOINT DISPLAY

Eix Evapin Temp
 Eox EvapOut Temp
 CFx Configuration (0 - F)
 SPx Backup Setpoint (10 - 90)
 LPx Low Pressure time Delay (10 - 120 sec)

Note: 'x' represents the displayed zone number. The display will revert back to the NORMAL display after approximately 10 sec.

3. **UP ARROW:** depress this push button to increase the parameter displayed in the SETUP window. If this push button is pressed momentarily, the value is incremented by one. If the push button is held down for more than one second, the value will increase slowly at first and then faster after about two seconds.
4. **UP ARROW:** depress this push button to decrease the parameter displayed in the SETUP window. If this push button is pressed momentarily, the value is decremented by one. If the push button is held down for more than one second, the value will decrease slowly at first and then faster after about two seconds.
5. **Note:** When setting the Low Pressure Dela or Backup Setpoint on the zone boards, press the UP or DOWN buttons to keep the display from timing out and reverting back to the default to PROCESS mode.
6. **POWER:** this LED indicates when the power to the unit is turned on.
- 7.. **POWER ON LED:** Indicates that power is applied to the controller board.

M. MZCIII ZONE BOARD

1. INTRODUCTION

- a. The Zone Board is used to interface from the Controller Board to the chiller system compressors, bypass valves and safety switches.
- b. Communications with the MZC Controller Board is via an RS-485 network. If communications with the Controller Board fails the Zone Board will switch to a stand-alone mode and maintain control of the system independent of the MZC Controller board based on the value of the Alternate Setpoint Potentiometer.

2. USER CONTROLS

a.. ZONE AC POWER SWITCH (Toggle Switch)

‘ON’: Applies 110VAC power to Safety Switches and AC OUTPUT’s

‘OFF’: Disconnects 110VAC power from Safety Switches and ACOOUTPUT’s

b. ADDRESS SWITCH (Rotary Switch)

Selects address of ZONE Board from 1 to 7, 0 is not used for normal operation

NOTE: Each ZONE BOARD in the system must be set to a different address.

3. CONFIGURATION SWITCH (Rotary Switch)

Selects configuration number from 0 to F.

4. LOW PRESSURE TIME DELAY POTENTIOMETER

Adjust value of low-pressure time delay from 10 to 120 seconds.

5. Alternate Setpoint Potentiometer

Adjust value of alternate setpoint from 10 to 90. This setpoint is **ONLY** used when the RS-485 communications with the Controller Board is not working properly.

6. STATUS DISPLAY SECTION

LED displays that indicate the status of the chiller.

a. **POWER LED:** Indicates that 12VDC power is applied to the Zone Board.

b. **SAFETY/PROTECTION LED's**

OIL: Low oil pressure safety switch fault.

COMP: Compressor motor overload fault.

HP: Refrigerant high-pressure safety switch fault.

FREEZE: Freezestat safety switch fault.

LF: Low water flow switch fault.

LP: Refrigerant low -pressure safety switch fault

ZONE: Zone Board 110VAC power switch is 'ON'.

c. **AC OUTPUT LED's**

See Configuration Matrix Chart for description of **OUTPUT LED's**. The state of these **LEDs** should correspond with the **OUTPUT CONTROL LEDs** on the **MZC** Controller Board.

OUT 1: Indicates output status of OUT 1

OUT 2: Indicates output status of OUT 2

OUT 3: Indicates output status of OUT 3

OUT 4: Indicates output status of OUT 4

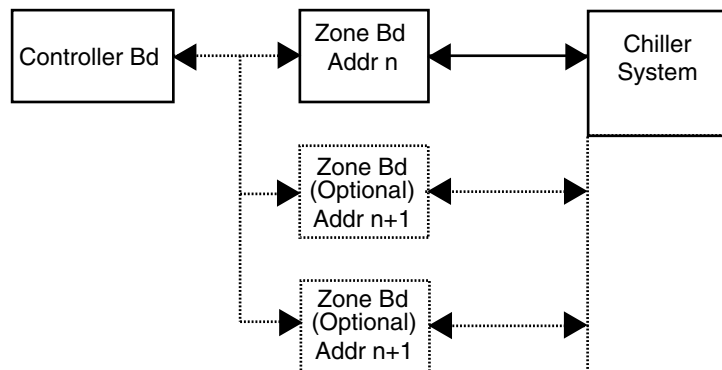

Note: n= 1 to 7

7. INTERFACE SECTION

a. **SAFETY/PROTECTION CONNECTOR**

Electrical connections to safety switches.

OIL: Low oil pressure safety switch.
COMP: Compressor motor overload safety switch.
HP: Refrigerant high-pressure safety switch.
FREEZE: Freezestat safety switch.
LF: Low water flow switch fault.
LP: Refrigerant low -pressure safety switch.
ZONE: Zone Board 110 AC power input.

b. AC OUTPUT CONNECTOR

Electrical connections to AC outputs. See Configuration Matrix Chart for description of OUTPUT's.

OUT 1: output 1 AC Connection
OUT 2: output 2 AC Connection
OUT 3: output 3 AC Connection
OUT 4: output 4 AC Connection

c. DC POWER SUPPLY/COMMUNICATIONS CONNECTOR

PWR: 12VDC+
GND: 12VDC GND
GND: 12VDC GND
+: RS-485 + TXS/RXD to Controller Board
-: RS-485 - TXS/RXD to Controller Board
GND: RS-485 GND

d. INTERFACE SECTION (continued)

OUT BLK: 12VDC+
OUT WHT: 12VDC GND
IN BLK: 12VDC GND
+: RS-485 + TXS/RXD to Controller Board
-: RS-485 - TXS/RXD to Controller Board
GND: RS-485 GND

e. EVAPORATOR TEMPERATURE PROBE INPUT CONNECTOR

OUT BLK: Evaporator out temperature probe.
OUT WHT: Evaporator out temperature probe.
IN BLK: Evaporator in temperature probe.
OUT WHT: Evaporator in temperature probe.

Configuration Matrix Chart

Conf. Setting	OUT1	OUT2	OUT3	OUT4
0	COMPRESSOR	RESERVED	RESERVED	HGBP
1	COMPRESSOR	UNLOADER	RESERVED	HGBP
2	COMPRESSOR	UNLOADER	UNLOADER	HGBP
3	COMPRESSOR	UNLOADER	RESERVED	RESERVED
4	COMPRESSOR	UNLOADER	UNLOADER	RESERVED
5	COMPRESSOR	COMPRESSOR	RESERVED	HGBP
6	SCREW COMPRESSOR	SOLENIOD 2	SOLENIOD 3	SOLENIOD 4
7	SCREW COMPRESSOR	SOLENIOD 1	SOLENIOD 2	RESERVED
8*	COMPRESSOR	RESERVED	RESERVED	HGBP
9*	COMPRESSOR	UNLOADER	UNLOADER	HGBP
A*	COMPRESSOR	UNLOADER	RESERVED	HGBP
B*	COMPRESSOR	UNLOADER	UNLOADER	RESERVED
C*	COMPRESSOR	UNLOADER	RESERVED	RESERVED
D*	COMPRESSOR	COMPRESSOR	RESERVED	HGBP
E	SCREW COMPRESSOR	SOLENIOD 2	SOLENIOD 3	SOLENIOD 4
F	SCREW COMPRESSOR	SOLENIOD 1	SOLENIOD2	RESERVED

* Allow units with a remote condenser to start in low ambient/low pressure condition.

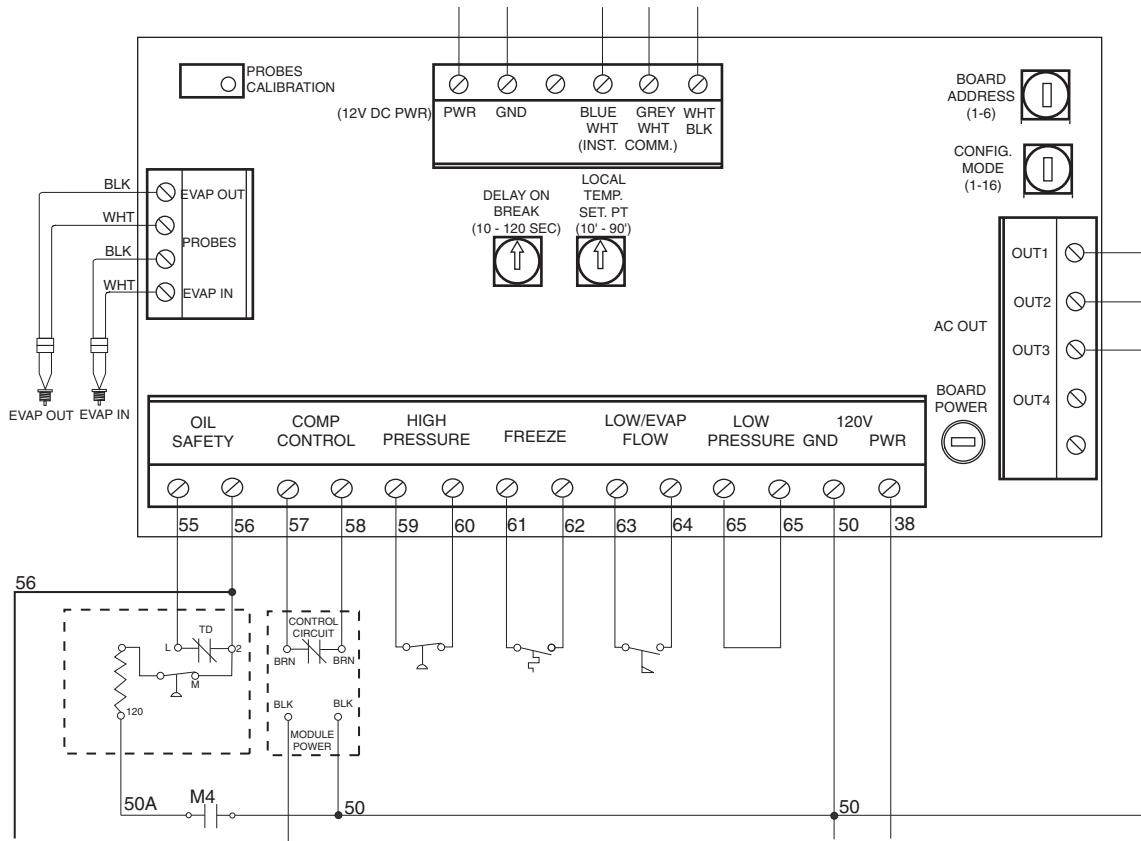

3.6 UNIT SHUT DOWN/DISCONNECT SEQUENCE

A. PRECAUTIONS/WARNINGS

1. The operator must precisely follow all shut down procedures outlined in this manual. If the operator fails to follow precisely all procedures outlined in this manual, an unsafe condition can develop resulting in damage to the unit or personal injury.

B. UNIT SHUT DOWN

1. **To shut down the unit without disconnecting from the process:**
 - a. Turn off the unit..
 - b. Maintain electrical power to the unit at all times except for service purposes.
2. **To shut down the unit and disconnect from the process:**
 - a. Turn off the unit.
 - b. Disengage the electrical supply to the chiller at the disconnecting device.
 - c. Disconnect all process lines.

THIS PAGE INTENTIONALLY BLANK

4.0 TROUBLESHOOTING

- 4.1 UNIT WILL NOT START
- 4.2 COMPRESSOR HUMS BUT WILL NOT START
- 4.3 SHUTS OFF ON HIGH PRESSURE
- 4.4 SHUTS OFF ON LOW PRESSURE
- 4.5 COMPRESSOR SHUTS OFF ON INTERNAL OVERLOAD
- 4.6 LOW OR NO PROCESS PRESSURE OR WATER FLOW
- 4.7 COOLING CAPACITY INADEQUATE
- 4.8 SENSOR
- 4.9 PUMPS
- 4.10 OIL PRESSURE
- 4.11 CRANKCASE HEATER
- 4.12 CHILLER CONTROLLER



4.1 UNIT WILL NOT START

- A. **Power off.** Check main disconnect.
- B. **Main line open.** Check fuses.
- C. **Loose terminals.** Tighten terminals with POWER OFF.
- D. **Control circuit open.** check control voltage fuses and transformer.

4.2 COMPRESSOR HUMS BUT WILL NOT START

- A. **Contactor.** Check contacts and contactor operation.
- B. **Low voltage.** Check voltage at main and at the unit. If voltage is OK at the main but low at the unit, increase wire size. If low at main, consult your local power company. Voltage must be +/- 10% nameplate rating.
- C. **No power on one phase of a three phase unit.** Check fuses in control panel and main disconnect. Also check unit wiring, main plant fuse and wiring. If the problem is with the main power supply coming into the plant, call the local power company.
- D. **Loose terminals.** Tighten terminals with POWER OFF.

4.3 SHUTS OFF ON HIGH PRESSURE CONTROL

- A. **Note.** Refrigerant high pressure will vary with ambient operating temperature from minimum of 190 psi to as high as 280 psi. The high pressure switch manually reset when discharge pressure falls to a safe level. The switch is located inside the electrical panel.
 - 1. **Insufficient condenser air flow.** Check condenser filter for dirt, fins may be plugged with dirt or foreign material. Also, check for proper fan rotation.

Note: all enclosure panels must be attached.
 - 2. **Fan motor not operating.** Have electrician check fuses and wiring, motor starter and overloads, and motor. Repair or replace motor if defective.
- B. **Improperly set high pressure control.** Have refrigeration serviceman reset or replace the control if defective.

4.4 SHUTS OFF ON LOW PRESSURE CONTROL

After the refrigerant pressure rises above the cut-in pressure, a three minute time delay will occur before the compressor restarts. This will protect the evaporator and compressor from damage should a problem occur in the refrigeration system or if the chiller is operated under circumstances which could cause damage to the refrigeration system.

Note: The low pressure switch will automatically resets when the pressure rises above the cut-in pressure. If this does not occur contact the the Manufacturer's service department for instructions.

Note: The low pressure switch should be set according to the ambient operating temperature, as specified in section 8.1 of this manual.

If a low pressure condition exists for more than five seconds the compressor will stop and a "L-P" fault will appear in the display window.

- A. **Low refrigerant charge.** Check for adequate refrigerant charge (bubbles or misty sight glass indicates low charge). If charge is low, have system checked for leaks and recharged by a refrigeration serviceman.
- B. **Improperly set low pressure switch.** Have a refrigeration serviceman reset control or replace if defective.
- C. **Restriction in the liquid line.**
 - 1. **Clogged filter drier.** Check for pressure or temperature drop and have drier core replaced by a refrigeration serviceman.
 - 2. **Liquid line valve or suction valve on compressor is partially closed.** Open fully.
 - 3. **Liquid line solenoid not opening fully or leaking during off cycle.** Have valve repaired or replaced if defective by a refrigeration serviceman.
 - 4. **Expansion valve plugged or inoperative.** Check thermal bulb and capillary tube for damage. Have repaired or replaced if defective by a refrigeration serviceman.

4.5 COMPRESSOR SHUTS OFF ON INTERNAL OVERLOAD

- A. **Control does not reset.** Have compressor windings and internal solid state safety control checked by a refrigeration serviceman. Have it repaired or replace if defective.

4.6 LOW OR NO PROCESS PRESSURE OR WATER FLOW

- A. **Valves.** Check if water valves are open.
- B. **Pump.** Check pump for correct rotation. Check pump suction for restriction. Replace motor if defective.
- C. **Filters.** Check filter in the chilled water circuit and clean if necessary.
- D. **Pressure switch (or flow switch).** Readjust or replace if defective.
- E. **Fuses and wiring.** Have electrician check the fuses and wiring.

4.7 COOLING CAPACITY INADEQUATE

- A. **Low refrigerant charge.** Check for adequate refrigerant charge (bubbles or misty sight glass indicates low charge). If charge is low, have system checked for leaks and recharged by a refrigeration serviceman.
- B. **Hot-gas bypass valve stuck open.** Have repaired or replace if defective by a refrigeration serviceman.
- C. **Expansion valve plugged or inoperative.** Check thermal bulb and capillary tube for damage. Have repaired or replaced if defective by a refrigeration serviceman.
- D. **Plugged filter.** Check filter in chilled water circuit and clean.
- E. **Air in system.** Purge air.

4.8 SENSOR

The sensor is a solid state temperature transducer which converts temperature input to proportional current output. To quickly test for a defective probe, switch connections between the defective probe and a probe known to be working properly. A defective sensor will display a "---" in the display window on the instrument control.

4.9 COOLANT PUMP

- A. The centrifugal pump is designed to operate at a specific flow and pressure at the maximum run load amp draw of the motor. Too much flow can overload the motor and cause the overload circuit to open and stop the pump.
- B. If the overload trips, check for electrical shorts, loose wires, or

blown fuses. If these check OK, reset the overload circuit and restart the chiller.

- C. Check the amp draw and if overloaded, partially close the from process line valve until the amp draw drops to the proper level.

4.10 OIL PRESSURE

- A. This switch must be manually reset after the problem is resolved.
- B. Check for low oil level in the compressor crankcase or insufficient compressor warm up before start-up.
- C. Defective crankcase heater, internal compressor damage causing the compressor to pump too much oil through the system, defective oil pump, or plugged pick up screen in compressor oil sump. **Note:** only semi-hermetic compressors 15-30 tons have an oil pressure safety switch.

4.11 CRANKCASE HEATER

- A. If the crankcase heater is not drawing current during the compressor off cycle, check for a defective crankcase heater, defective fuses or defective interlock on the compressor starter.
- B. Scroll compressors do not have crankcase heaters.

4.12 CHILLER CONTROLLER

- A. The display is used for all normal set ups, diagnostics, temperature readout, and operational information. **Note:** the display is not field repairable. It can be easily removed and replaced if required.
- B. The CPU contains the software and various electronic components which make the instrument work. **Note:** the CPU is not a field repairable part. It can be easily removed and replaced if a problem arises.

THIS PAGE INTENTIONALLY BLANK

5.0 MAINTENANCE

- 5.1** WARRANTY SERVICE PROCEDURE
- 5.2** PERIODIC PREVENTATIVE MAINTENANCE
- 5.3** SPECIAL MAINTENANCE
- 5.4** SOLENOID VALVE SERVICE
- 5.5** PUMP SEAL SERVICE
- 5.6** CHECKING THE REFRIGERANT CHARGE
- 5.7** PROPER CLEANING PROCEDURE FOR BRAZED PLATE EVAPORATOR



5.1 WARRANTY SERVICE PROCEDURE

- A. In the event of a problem with a chiller that can not be resolved by normal troubleshooting procedures, the customer is invited to consult the Service Department for assistance. The correct model number and serial number of the chiller must be available. The service department will attempt to isolate the problem and advise repair procedures. Often times, with the customer's input and with the machine diagnostics, problems can be determined with "over-the-phone" consultation.
- B. If the problem is beyond the scope of "over-the-phone" consultation, and if the warranty status of the machine is valid, the Manufacturer will contact the nearest authorized service contractor and provide authorization to conduct an "on-site" inspection of the unit in order to determine the course of repair. If the chiller is not covered by the warranty, the Manufacturer will advise on the repair and recommend available service contractors.
- C. It is of the utmost importance that you provide the correct model number and serial number of the machine in question. This will allow the Service Department to obtain the correct manufacturing records which will help to properly troubleshoot the problem and obtain the proper replacement parts when they are required. This information is stamped on the data tag that is attached to the electrical enclosure of each machine.
- D. The Service Department must be notified prior to any repair or service of a warranty nature. Warranty claims will not be honored without prior authorization.

5.2 PERIODIC PREVENTATIVE MAINTENANCE

- A. Lubricate all motors. Note that some motors are supplied with sealed bearings.
- B. Tighten all wire terminals. Look for discolored terminals and loose wires.
- C. Clean and check motor starter and contactor contacts.
- D. Check safety switch settings.
- E. Clean condenser fins of dust and dirt.
- F. Back flush evaporator.
- G. Check glycol/water solution ratio for operating temperature.
- H. Check system for leaks.

- I. Refrigerant sight glass. Check for bubbles when compressor is operating at 100%. Check the moisture indicator for a color other than green.
- J. Check all refrigeration lines for worn or bright spots on tubing. Check for refrigerant leaks. Refrigerant leaks normally leave traces of oil.
- J. Clean unit.

5.3 SPECIAL MAINTENANCE

- A. Any service of the refrigeration system must be accomplished by a certified refrigeration technician. Refrigeration systems are fully pressurized at all times and should only be serviced by trained personnel.
 - 1. Addition of compressor oil.
 - 2. Addition of refrigerant.
 - 3. Repair of a refrigerant leak.
 - 4. Adjustment of super heat.
 - 5. Changing of filter-drier or drier core.
 - 6. Repair of a refrigeration solenoid.

5.4 SOLENOID VALVE SERVICE

- A.** Units with the water make-up system use a solenoid valve (figure 5.4A) to regulate flow into the reservoir tank. The solenoid valve is controlled by the float switch.
- B.** Generally, solenoid valves fail due to poor water quality, low water flow, or defective valve elements.
- C.** The operator should follow this procedure to service the make-up solenoid valve:

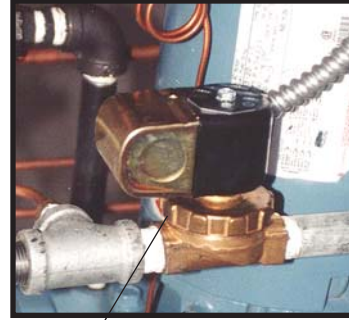

Typical water make-up solenoid valve

Figure 5.4A

1. Disengage process operations according to the procedure outlined in **section 3**. The operator must be certain process fluid temperature is under 100°F and pressure is relieved (pressure gauge reads “0”) and water system flow is shut off and all pressure relieved.
2. Disengage main power supply. The operator must verify the proper lockout procedures are followed.
3. Remove or open any access cover panel and set aside to gain access to the cooling solenoid valve.
4. The operator must be certain all water system pressure is relieved.
5. Identify the retaining screw (figure 5.4B) on the solenoid valve coil. Remove the screw. Keeping all electrical connections intact, lift the coil off of the enclosure tube and set aside.
6. Use a pair of channel lock pliers or a pipe wrench to separate the bonnet assembly from the valve body. The plunger is “loose” inside the enclosing tube. Be certain it is retained in the enclosure tube as the bonnet is removed (figure 5.4C).
7. Identify the diaphragm assembly. Gently remove the assembly from the valve body (figure 5.4D).

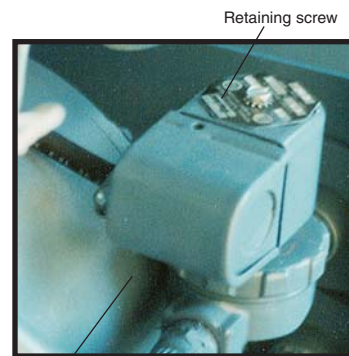

Coil

Figure 5.4B

8. Identify the mesh screen. Gently removed the mesh screen and clean or replace as necessary.
9. Clean the valve body.
10. Reset the mesh screen into the valve body.
11. If a new diaphragm assembly was obtained, continue with step 12. If not, disassemble the diaphragm assembly and note component order (figure 5.4E). Clean the valve port, plate, collar and O-ring. Once cleaned, reassemble the diaphragm.
12. Set the reassembled diaphragm assembly or the new assembly back into the valve body. The stem should be facing out of the valve body.
13. Inset the plunger with spring first into the enclosing tube of the top bonnet (figure 5.4F). Holding the plunger in the enclosure tube, set the top bonnet onto the valve body and tighten.
14. Place the coil onto the top bonnet and replace the retaining screw.
15. Open the water supply and drain valves (if installed) to circulate water through the supply and drain manifolds. Check the solenoid valve for leakage. Restart the unit as outlined in **section 3**.

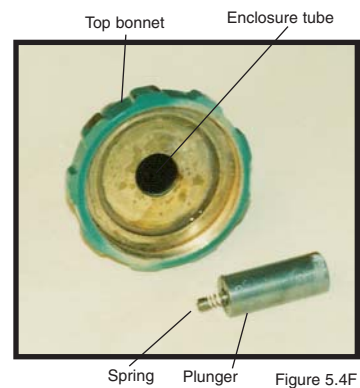
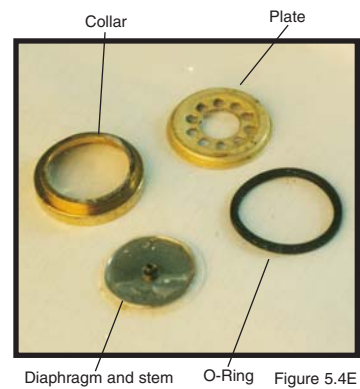
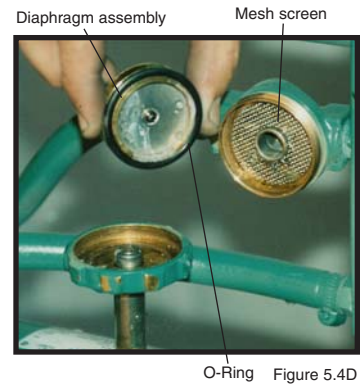
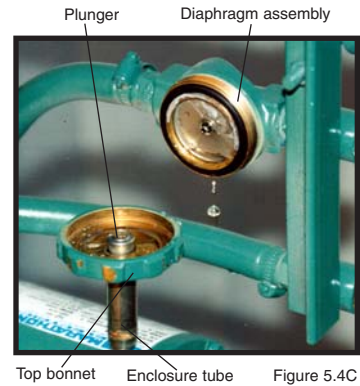

5.5 PUMP SEAL SERVICE

A. The coolant pump seal is a carbon/niresist shaft seal assembly including a stationary member, rotating member and tension spring (figure 5.5A).

B. The operator can determine the pump seal is leaking when fluid is identified leaking from the pump case adapter. Generally, a pump seal will leak due to inadequate unit pressure, excessive flow and poor fluid quality.

C. The operator should follow this procedure to replace the pump seal:

1. Disengage process operations according to the procedure outlined in **section 3.4**. The operator must be certain process fluid temperature is under 100°F and pressure is relieved (COOLANT pressure gauge reads “0”) and water make-up flow is shut off and all pressure relieved.
2. Disengage main power supply. The operator must verify the proper lockout procedures are followed.
3. Access the pump motor by opening or removing any cover panels as necessary (figure 5.5B).
4. Drain machine. The machine can be drained by using the drain valve located on the pump case. Drain fluid into a suitable container for reuse or disposal according to manufacturer’s instructions (if a glycol solution is used).
5. Locate and remove the three motor wire leads from the motor wiring terminals. The operator should “map”

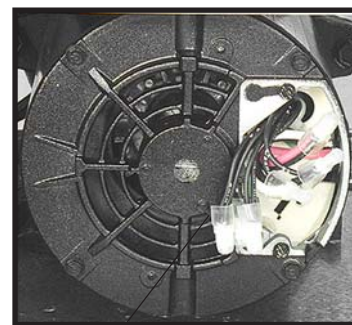
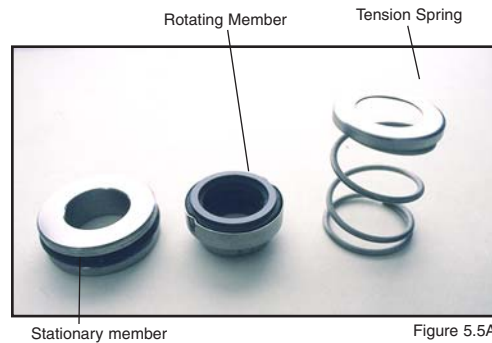

the wire terminal locations to ensure correct rewiring. The power cord should be removed from the motor housing (figure 5.5C).

6. Locate and remove the pump casing bolts. These bolts secure the motor and motor adapter to the pump casing (figure 5.5D).

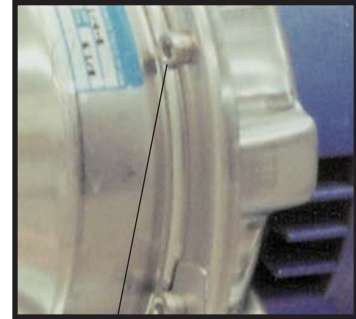

Typical pump casing bolt Figure 5.5D

7. Separate the motor and motor adapter from the pump casing to expose the pump impeller (figure 5.5E). Remove the motor and motor adapter from the unit and place on a workbench to continue the procedure.

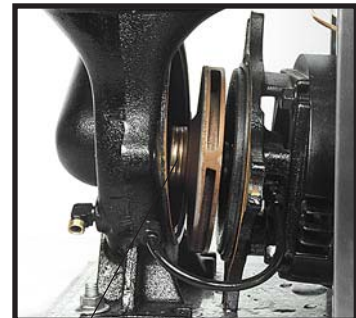

Impeller Figure 5.5E

8. Locate and remove the dust cap from motor end to expose slotted motor shaft. The motor shaft is free to rotate, but must be secured to remove the impeller. To secure the motor shaft, insert a flat bladed screw driver in slot to hold the shaft stationary (Figure 5.5F).



Motor shaft Figure 5.5F

9. Locate and remove impeller locking screw (Figure 5.5G). Using a socket and ratchet, the impeller retaining screw can be removed. Once the retaining screw is removed, the impeller can be "unthreaded" from the motor shaft to expose the pump seal assembly.

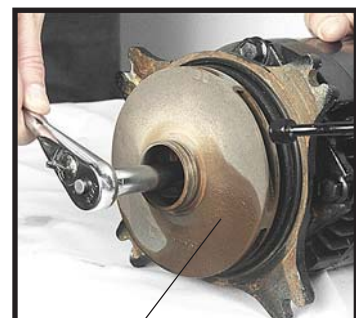

Typical impeller Figure 5.5G

10. Remove all seal parts (Figure 5.5H). Note seal component arrangement to facilitate reassembly.

11. Clean motor shaft and lubricate with a mild soap solution.
 12. Install new stationary seal member in pump casing cavity (figure 5.5I). The operator must be certain the stationary seal member is fully squared and seated in cavity.
 13. Slide the rotating member onto lubricated pump shaft (figure 5.5J). The operator must be certain not to damage or tear rubber bellows assembly.
 14. Place the spring onto the rotating member.
 15. Align the impeller, spring and rotating member before reinstalling the impeller (figure 5.5K). The operator must be certain the spring and rotating member are aligned before the impeller is fully tighten and the impeller retaining screw is reinstalled.
 16. Clean pump casing, cavities, impeller and O-ring before reassembly.
 17. Mate the motor and motor adapter to the pump casing. Reinstall the pump casing bolts.
 18. Reconnect the motor power cord and leads.
 19. Restore all cover panels as were removed.
- E. When the pump seal replacement procedure is complete, the operator may restart the unit according to the **section 3**.



Seal components

Figure 5.5H



Stationary member

Figure 5.5I



Stationary member

Figure 5.5J



Seal members

Figure 5.5K

5.6 CHECKING THE REFRIGERANT CHARGE

- A.** All standard chillers are manufactured with thermostatic expansion valves as the metering device to the evaporator.
- B.** All standard chillers have a refrigerant sight glass (figure 5.6A) with a moisture indicator. To check the refrigerant charge under normal operating conditions:

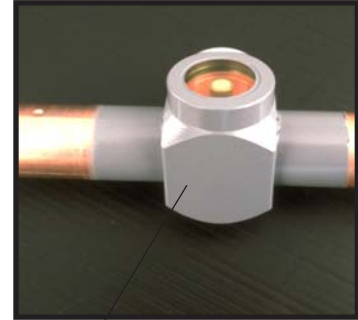

Sight Glass

Figure 5.6A

1. Remove the plastic cap covering the sight glass.
2. Start the chiller and allow system pressures and temperatures to stabilize.
3. With the unit operating at 100% capacity (not in the “capacity control” mode) the sight glass should appear clear with no foam or bubbles evident. If foam or bubbles are evident, the chiller has suffered from a loss of refrigerant and should be checked by a qualified refrigeration technician.
4. The “dot” in the middle of the sight glass is the moisture indicator. It should appear green at all times. A white or yellow color indicates moisture has invaded the refrigeration system, which is detrimental to the life of the compressor. The filter-drier should be replaced by a qualified refrigeration technician.

5.7 PROPER CLEANING PROCEDURE FOR BRAZED PLATE EVAPORATORS

- A.** The brazed plate evaporator is made of stamped stainless steel plates, furnace brazed together with copper based joints. The complex geometry of the flow passages promotes turbulent flow which gives high efficiency and reduces fouling by mineral deposits. Large solids such as plastic pellets or chunks of mineral deposits will collect at the water inlet port at the evaporator and restrict flow through some of the passages. If this possibility exists, the Manufacturer recommends filters or strainers be added to the “from process” line. If the evaporator becomes fouled there are a couple of methods for cleaning.

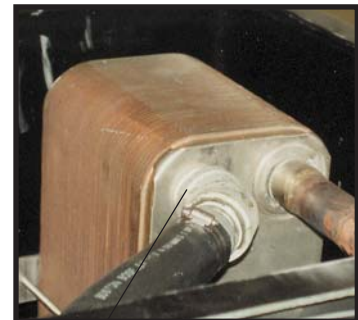

Evaporator

Figure 5.6A

B. To begin, remove the piping to the “water in” port at the evaporator. Remove any solids that have collected at this point. Then back flush the evaporator to remove any solids that may be trapped between the plates (see back flush procedure below). If there are mineral deposits adhered to the plates, the evaporator must be back flushed with a mild acid solution (5% phosphoric or 5% oxalic acid is recommended.) After cleaning rinse with clear water before returning to service. Continue with step C on the next page.

C. Back flushing procedure:

1. Turn off all power to the machine. For chillers with a reservoir tank, drain the tank to below the evaporator outlet. For chillers without a reservoir tank, drain total unit.
2. Connect a water supply hose to the evaporator water outlet. If acid cleaning, connect the discharge hose from the acid pump to the evaporator outlet port.
3. Connect a hose to the evaporator water supply port and to an appropriate containment vessel. If acid cleaning, connect the evaporator water inlet port to an acid solution reservoir tank. Dispose of all back flush fluid according to local codes.
4. The cleaning fluid source should have at least 20 psi available. If acid cleaning, follow the instructions supplied with the acid solution carefully.
5. When the procedure is complete, reinstall all water lines to original factory orientation. Restart the unit and check for proper operation.
6. **Note:** this procedure is not normal maintenance. Maintaining proper water quality and filtration will minimize the need to back flush the evaporator.

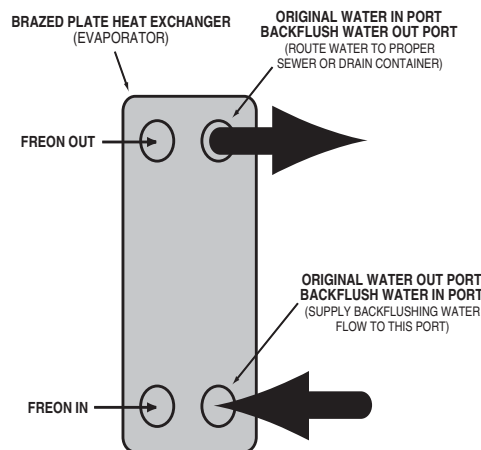

6.0 COMPONENTS

6.1 WATER SYSTEM

6.2 REFRIGERATION SYSTEM



6.1 WATER SYSTEM

- A. **PROCESS PUMP:** the motor/pump assembly circulates chilled fluid to the process loop. The pump assembly is built of total stainless steel to maintain water quality.
- B. **EVAPORATOR PUMP:** circulates water through the evaporator at a optimal and constant flow rate of 2.4 GPM per ton.
- C. **STANDBY PUMP:** (option) serves to 'replace' the process pump or the evaporator pump whenever service or maintenance on those pumps is required. Refer to section on valve orientation for standby pump operation, elsewhere in this manual.

6.2 REFRIGERATION SYSTEM

- A. **COMPRESSOR:** hermetic or semi-hermetic compressors take low pressure/low temperature refrigerant gas and compress the gas into high pressure/high temperature gas.
- B. **AIR COOLED CONDENSER:** the air cooled condenser removes BTU's from the compressed refrigerant gas. The action causes the gas to "condense" into a liquid state still under high pressure. Air flow across the condenser is achieved via a motor driven fan assembly or centrifugal blower.
- C. **FILTER-DRIER:** the filter-drier removes contaminants and moisture from the liquid refrigerant.
- D. **LIQUID LINE SOLENOID VALVE:** controlled by the instrument, this valve closes when the compressor cycles off to prevent refrigerant liquid from migrating to the evaporator. The valve opens when the compressor cycles on.
- E. **REFRIGERANT SIGHT GLASS:** the refrigerant sight glass indicates refrigerant charge and moisture content. Refrigerant charge is determined by a clear liquid flow. Bubbles indicate low refrigerant. Moisture content is indicated by the color of the element. Element color is normally green. If the color of the element is chartreuse or yellow, the system has been contaminated with moisture. In such case, the filter-drier must be replaced. The replacement of the filter-drier must be completed by a qualified refrigerant service technician.
- F. **EXPANSION VALVE:** the expansion valve throttles flow of refrigerant liquid into the evaporator and creates a pressure drop in the refrigerant system that allows the liquid refrigerant to "boil off" inside the evaporator.
- G. **EVAPORATOR:** the evaporator is a brazed plate heat exchanger where the refrigerant liquid is allowed to evaporate (boil off) to

absorb heat (BTU) from the process fluid. As the heat is absorbed, the process fluid is chilled.

- H. **HOT GAS BY-PASS SOLENOID:** the hot gas by-pass solenoid prevents short cycling of the compressor by reducing the capacity by 50% when the process fluid temperature nears the setpoint.
- I. **HIGH/LOW PRESSURESTATS:** the high/low pressurestats protect the refrigeration system from unsafe operating levels. The **high pressure switch** is factory set to open at 325 psi and protects the refrigeration components and personnel from potential damage of injury from excessive high pressure. The high pressure safety must not be altered in the field for any reason. The **low pressure switch** is factory set according to the operating ambient temperature as The low pressure switch protects the chillers from possible damage due to low operating pressure.

NEVER LOWER THE CUT OUT SETTING WITHOUT ADDING GLYCOL TO THE CIRCULATING SYSTEM. EVAPORATOR DAMAGE WILL RESULT AND WILL NOT BE COVERED BY THE WARRANTY.

- J. **LIQUID RECEIVER:** located after the condenser, this component receives and stores liquid refrigerant leaving the condenser.
- K. **SERVICE VALVES:** have been provided throughout the system. Only a qualified refrigeration service technician shall operate these valves.
- L. **CRANKCASE HEATER:** insures that freon and compressor crankcase oil do not mix during the compressor's "off" cycles. Power must be applied to the chiller previous to startup.
- M. **OIL PRESSURE SAFETY SWITCH:** protects the compressor from lubrication failure.

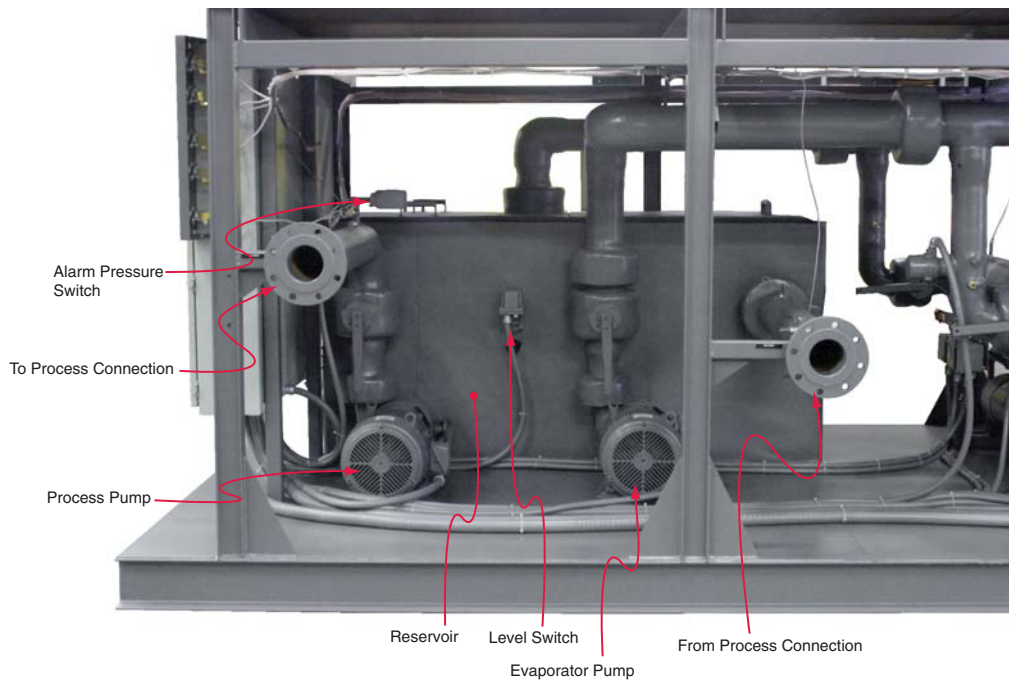
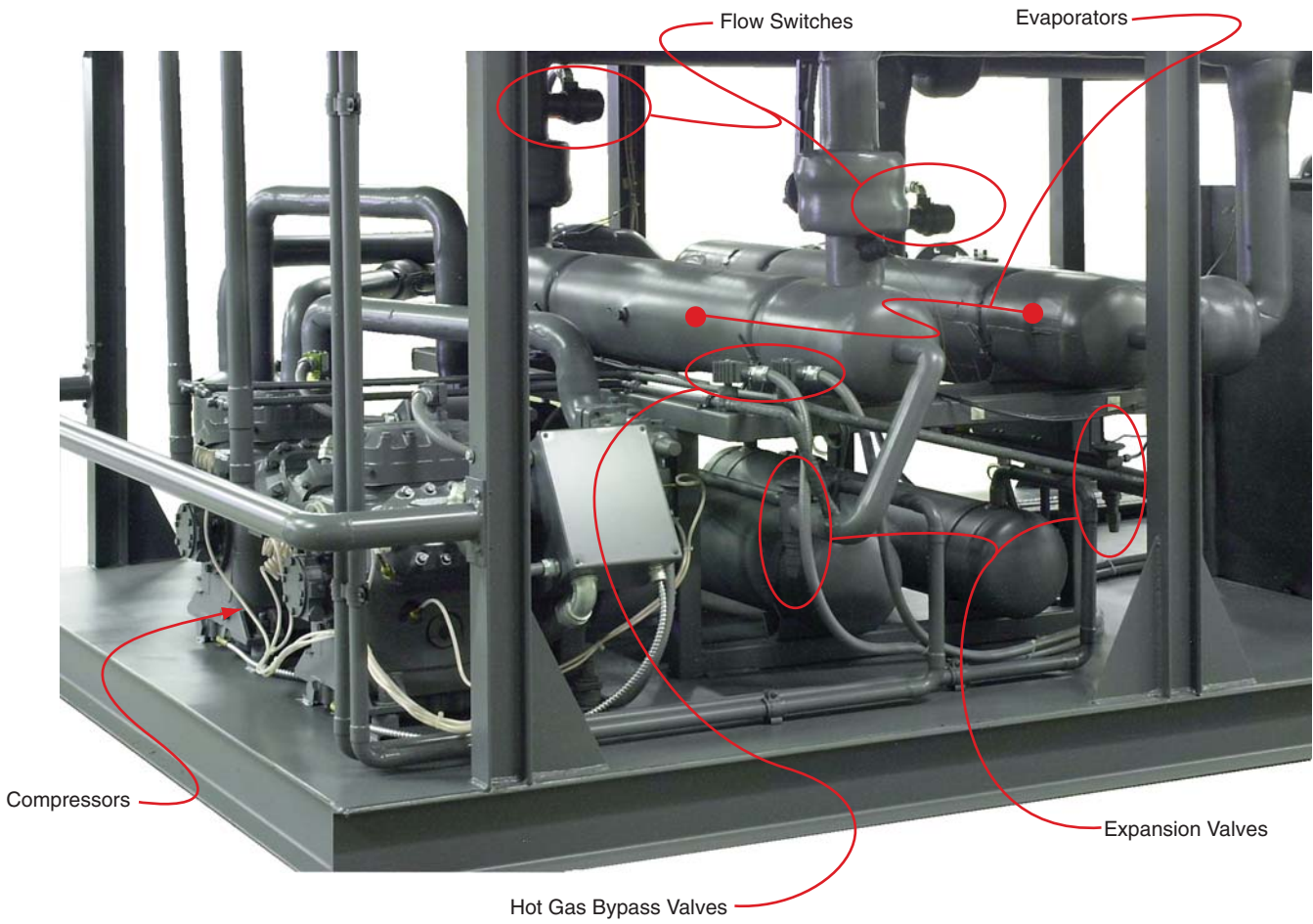

7.0 RELATED DRAWINGS

- 7.1** TYPICAL CIRCUIT SCHEMATIC
- 7.2** TYPICAL PHYSICAL DRAWING
- 7.3** ELECTRICAL DRAWING
- 7.4** TYPICAL PRESS DROP
- 7.5** TYPICAL VACUUM BREAKER / ANTI-SIPHON SYSTEM
- 7.6** TYPICAL LABEL PLACEMENT DRAWING
- 7.7** TYPICAL PANEL / CONTROL STATION DRAWING



7.1 TYPICAL CIRCUIT SCHEMATIC

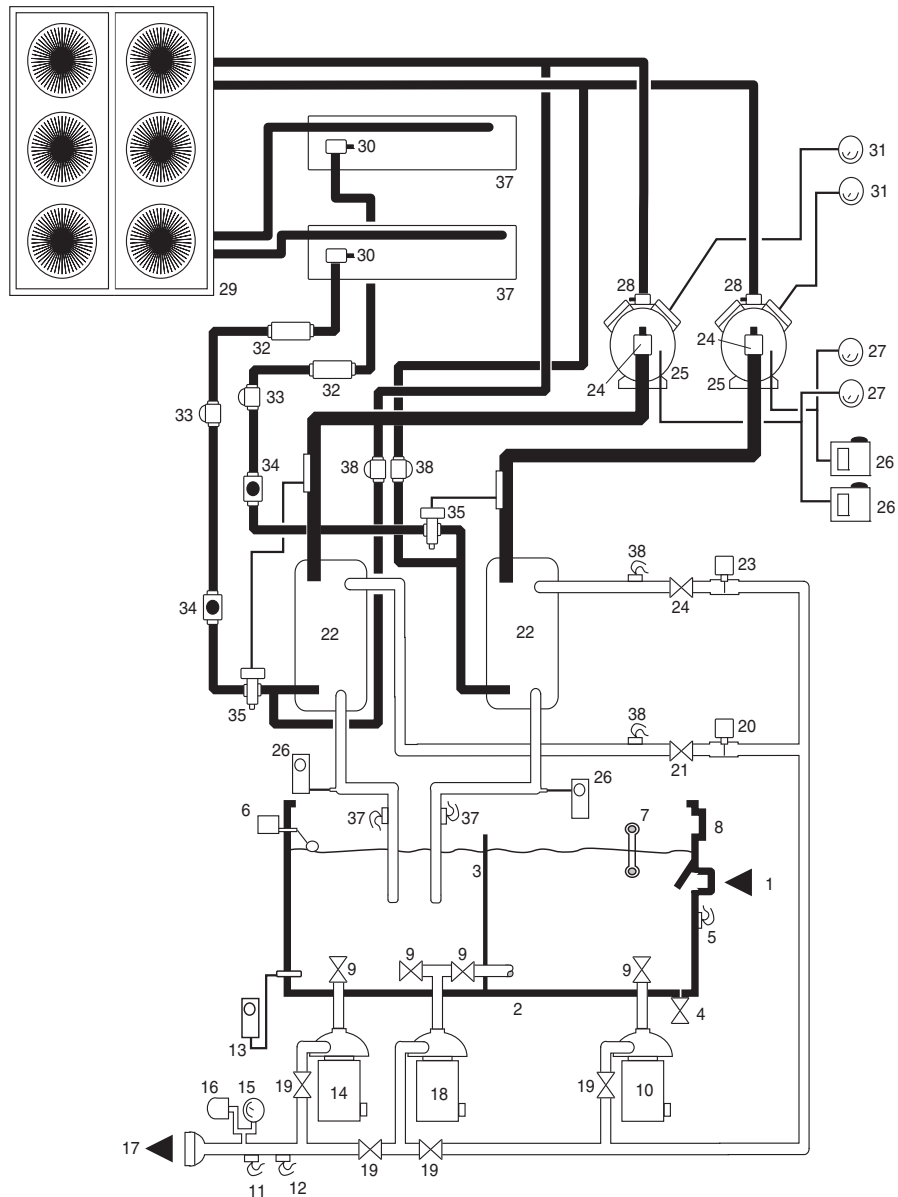

#	Item	#	Item	#	Item
1	From process connection	14	Process pump	28	Compressor discharge valve
2	Tank assembly	15	Supply pressure gauge	29	Condenser
3	Baffle plate	16	Alarm pressure switch	30	Service valve
4	Tank drain valve	17	To process connection	31	Head pressure gauge
5	Return probe	18	Standby pump	32	Filter-drier
6	Tank level control	19	Pump discharge valve	33	Liquid line solenoid valve
7	Level sight glass	20	Flow safety switch	34	Refrigerant sight glass
8	Overflow to drain	21	Factory adjusted flow control valve	35	Expansion valve
9	Pump suction valve	22	Evaporator	36	Hot gas by-pass valve
10	Evaporator pump	23	Freezestat	37	Evaporator out temperature sensor
11	Supply probe	24	Compressor suction valve	38	Evaporator in temperature sensor
12	Control sensor	25	Compressor		
13	Alarm thermostat	26	Low pressure safety switch		
		27	Low pressure gauge		

7.2 TYPICAL PHYSICAL DRAWING

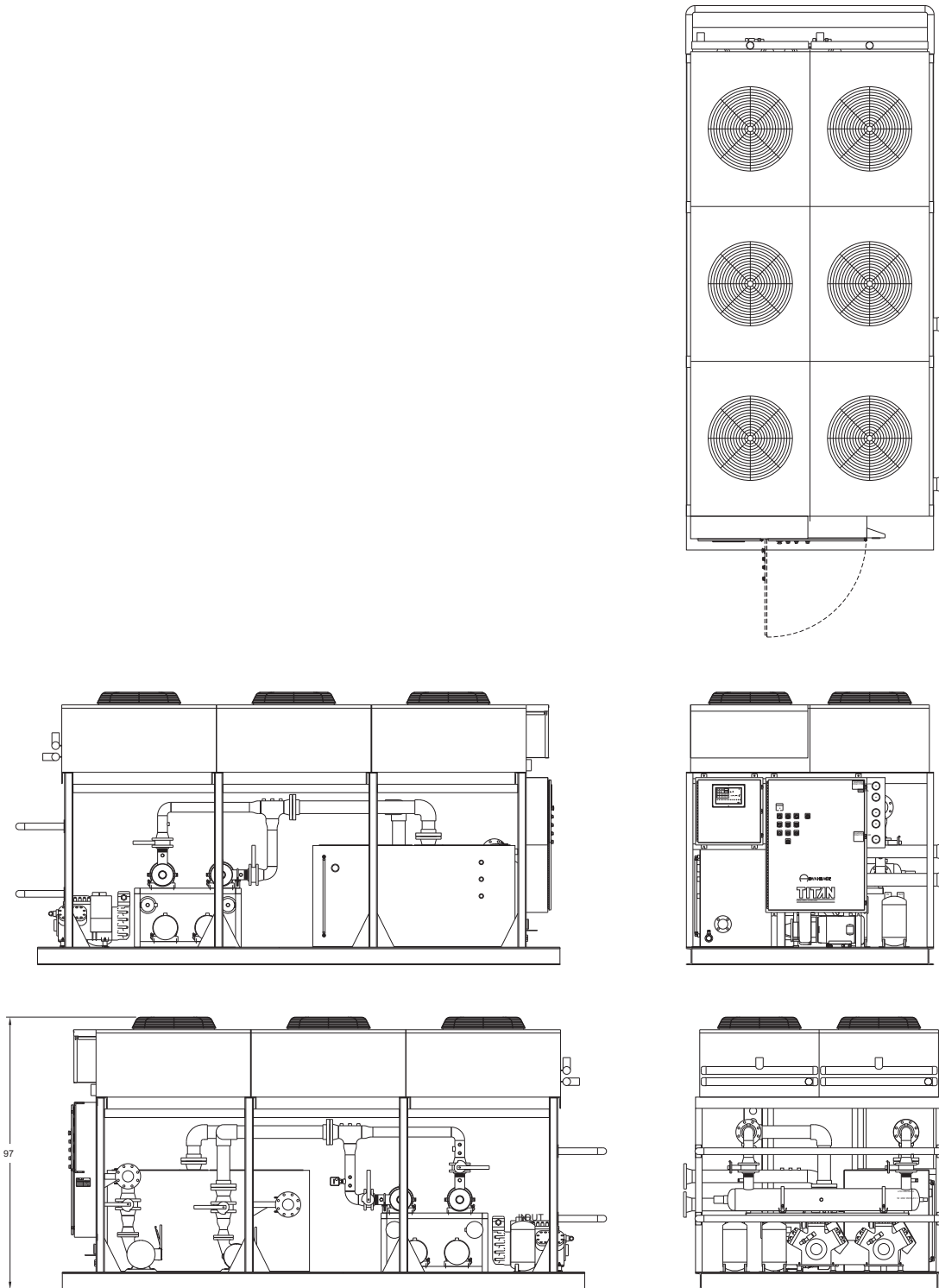

7.3 ELECTRICAL DRAWING

- A. The electrical drawing specific for the unit was provided with shipment of the unit. Please refer to this drawing.
- B. For duplicate drawings, please contact the Factory Service Department.



7.4 TYPICAL PRESS DROP

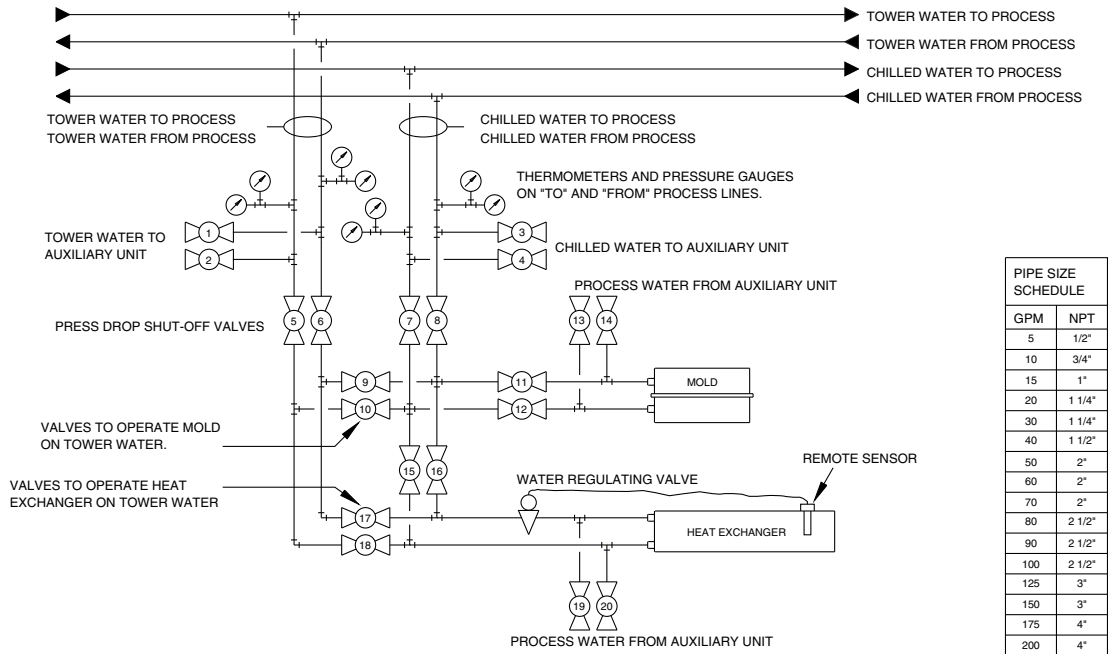

PIPE SIZE SCHEDULE	
GPM	NPT
5	1/2"
10	3/4"
15	1"
20	1 1/4"
30	1 1/4"
40	1 1/2"
50	2"
60	2"
70	2"
80	2 1/2"
90	2 1/2"
100	2 1/2"
125	3"
150	3"
175	4"
200	4"

VALVE POSITION CHART	
CONDITION	VALVES OPEN
WATER SUPPLY TO AUXILIARY EQUIPMENT	1,2,3,4
TO RUN TOWER WATER ON MOLD	5,6,9,10,11,12
TO RUN CHILLED WATER ON MOLD	7,8,11,12
TO RUN AUXILIARY EQUIPMENT ON MOLD	13,14
TO RUN TOWER WATER ON HEAT EXCHANGER	5,6,17,18
TO RUN CHILLED WATER ON HEAT EXCHANGER	7,8,15,16
TO RUN AUXILIARY EQUIPMENT ON HEAT EXCHANGER	19,20

- NOTES:
- 1) GPM @ 40 psig, 10°FΔT
 - 2) INSTALL SERVICE UNIONS AND GAUGES AS REQUIRED.
 - 3) INSULATE ALL CHILLED WATER PIPING.
 - 4) PIPE SIZES ARE BASED ON FLOW RATES AND PRESSURE REQUIREMENTS. (SEE SCHEDULE)
 - 5) SEE VALVE POSITION SCHEDULE FOR OPEN REQUIREMENTS (ALL OTHER VALVES ARE CLOSED). MORE THAN ONE CONDITION MAY EXIST AT ONE TIME, WITH THE EXCEPTION OF MIXING TOWER AND CHILLED WATER SYSTEMS.

7.5 TYPICAL VACUUM BREAKER / ANTI SIPHON SYSTEM

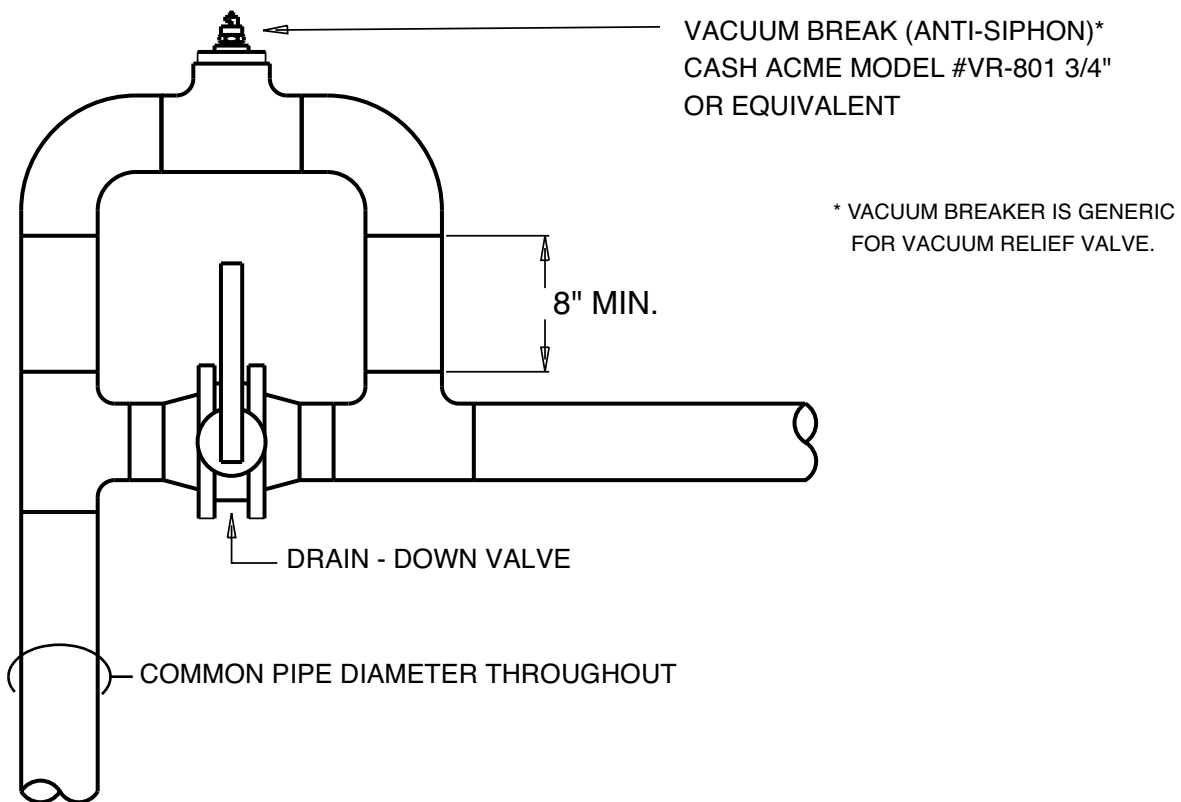

INSTALLATION NOTES:

1. The purpose of the vacuum breaker/anti-siphon (also called a drain-back dam), is to retain water in the header system during shut-down, and to eliminate air purge and shock to plumbing during start-up.
2. It is necessary to duplicate this arrangement on both the supply and return lines.
3. The drain-down valve allows header drainage for system maintenance and is closed during normal operation.
4. The vacuum breaker must be located at the highest point in the system, nearest to the tank to be most effective. A nipple length of 8 inches minimum is required to create sufficient vacuum to open the Cash Acme model VR-801.

7.6 TYPICAL LABEL PLACEMENT DRAWING

LP-1452	LABELS	OACS-80AD 2842SF
ITEM QTY	DESCRIPTION	
A	1	LIQUID LEVEL
B	1	FILL PORT
C	1	DRAIN
D	1	HIGH VOLTAGE WARNING
E	1	MADE IN AMERICA
F	1	HIGH PRESSURE WARNING
G	1	HEAD PRESSURE, ZONE #1
H	1	LOW PRESSURE, ZONE #1
I	1	HEAD PRESSURE, ZONE #2
J	1	LOW PRESSURE, ZONE #2
K	1	PRESSURE TO PROCESS
L	1	ADVANTAGE LOGO
M	1	TITAN LOGO
N	1	TO PROCESS
O	1	DATA TAG
P	1	PROCESS PUMP
Q	1	EVAPORATOR PUMP
R	1	FROM PROCESS
S	1	EMERGENCY STOP
T	1	MASTER SWITCH OFF/ON
U	1	POWER ON
V	1	ALARM INACTIVE/ACTIVE
W	1	FAULT
X	1	PROCESS PUMP OFF/ON
Y	1	PROCESS PUMP ON
Z	1	PROCESS PUMP OVERLOAD
AA	1	EVAP. PUMP OFF/ON
BB	1	EVAP. PUMP ON
CC	1	EVAP. PUMP OVERLOAD
DD	1	SUMP HEATER ON

LP-1452	LABELS	OACS-80AD 2842SF
ITEM QTY	DESCRIPTION	
R	1	FROM PROCESS
S	1	EMERGENCY STOP
T	1	MASTER SWITCH OFF/ON
U	1	POWER ON
V	1	ALARM INACTIVE/ACTIVE
W	1	FAULT
X	1	PROCESS PUMP OFF/ON
Y	1	PROCESS PUMP ON
Z	1	PROCESS PUMP OVERLOAD
AA	1	EVAP. PUMP OFF/ON
BB	1	EVAP. PUMP ON
CC	1	EVAP. PUMP OVERLOAD
DD	1	SUMP HEATER ON

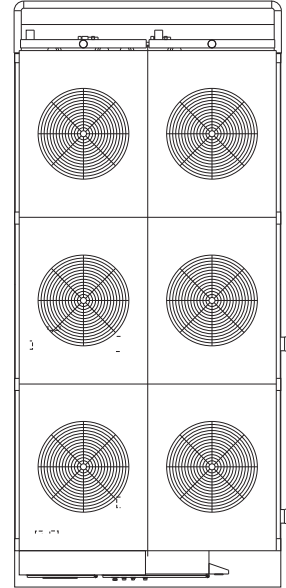
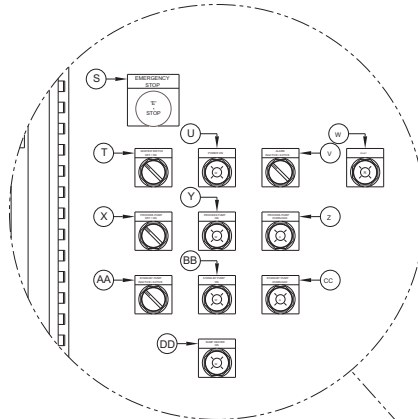

TOP VIEW

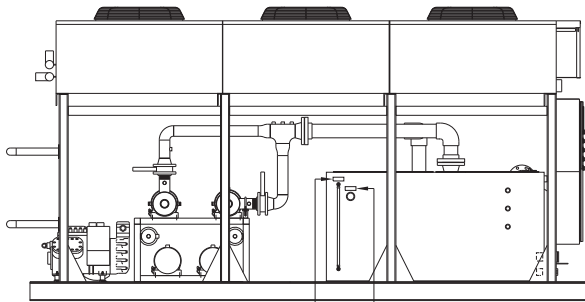

SIDE VIEW

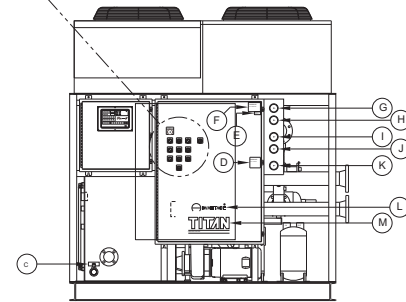

FRONT VIEW

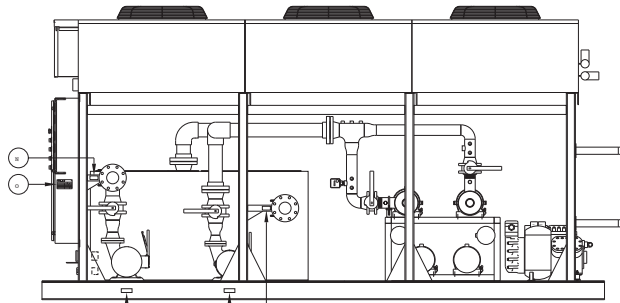

SIDE VIEW

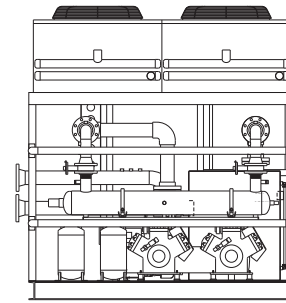

SIDE VIEW

7.7 TYPICAL PANEL CONTROL STATION DRAWING

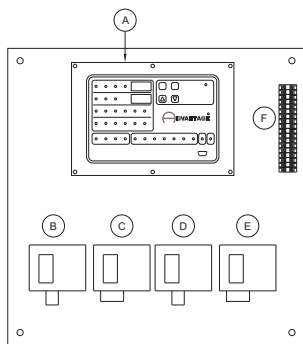
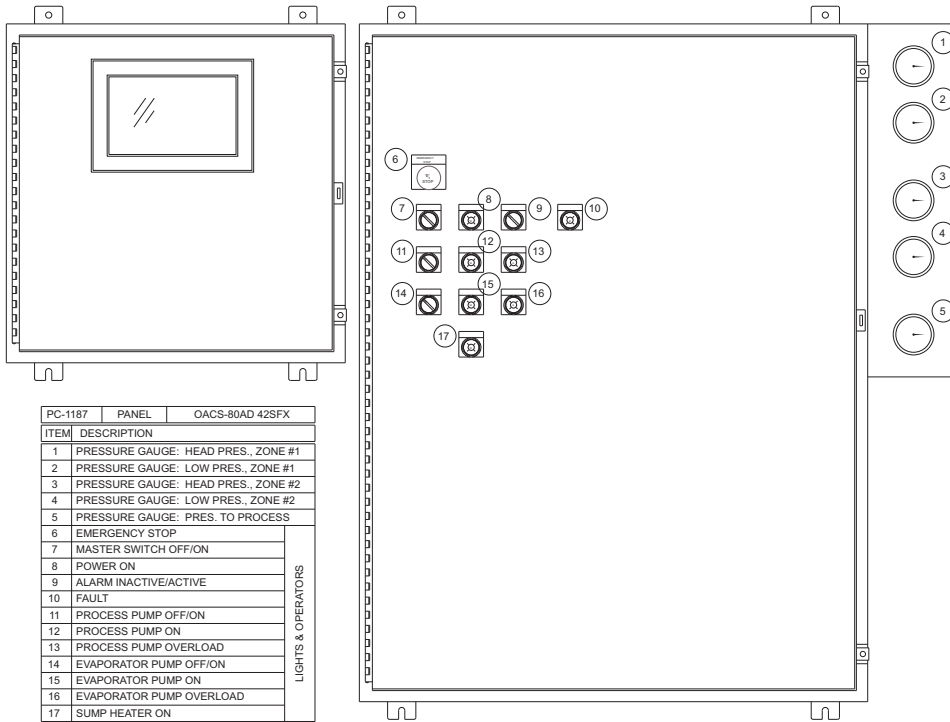

PC-1187	PANEL	OACS-80AD 42SFX
ITEM	DESCRIPTION	
A	INSTRUMENT: MZC-3	
B	REFRIGERANT HIGH PRES. SWITCH, ZONE #1	
C	REFRIGERANT LOW PRES. SWITCH, ZONE #1	
D	REFRIGERANT HIGH PRES. SWITCH, ZONE #2	
E	REFRIGERANT LOW PRES. SWITCH, ZONE #2	
F	TERMINAL STRIP	
G	BUS BAR	
H	INSTRUMENT: MZC-3 ZONE BOARD, ZONE #1	
I	INSTRUMENT: MZC-3 ZONE BOARD, ZONE #2	
J	INSTRUMENT TRANSFORMER	
K	FUSE BLOCK: FU-19,20	
L	CONTROL TRANSFORMER	
M	GROUND LUG	
N	POWER DISTRIBUTION BLOCK	
O	OIL PRESSURE SAFETY SWITCH, ZONE #1	
P	OIL PRESSURE SAFETY SWITCH, ZONE #2	
Q	SOLID STATE TIME DELAY RELAY: TANK LEVEL	
R	SOLID STATE TIME DELAY RELAY: HEATER	
S	RELAY: LOW LEVEL (R1)	
T	RELAY: ALARM/FAULT (R2)	
U	FUSE BLOCK: FU-16,17,18	
V	FUSE BLOCK: FU-13,14,15	
W	FUSE BLOCK: FU-10,11,12	

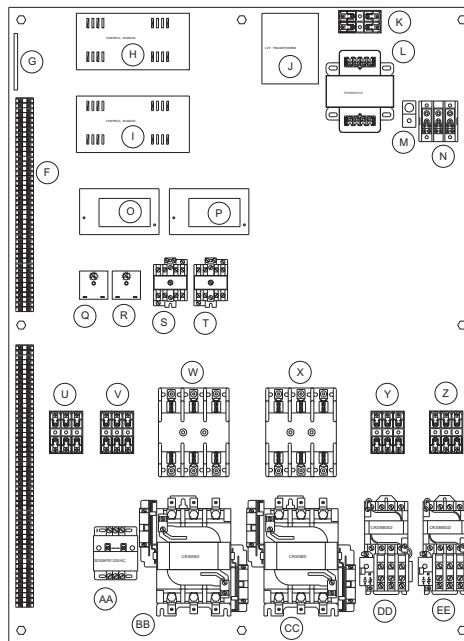

PC-1187	PANEL	OACS-80AD 42SFX
ITEM	DESCRIPTION	
X	FUSE BLOCK: FU-7,8,9	
Y	FUSE BLOCK: FU-4,5,6	
Z	FUSE BLOCK: FU-1,2,3	

PC-1187	PANEL	OACS-80AD 42SFX
ITEM	DESCRIPTION	
AA	HEATER CONTACTOR: H1	
BB	COMPRESSOR CONTACTOR: M4	
CC	COMPRESSOR CONTACTOR: M3	
DD	MOTOR STARTER: M2	
EE	MOTOR STARTER: M1	

8.0 APPENDIX

- 8.1** OPERATIONS BELOW 48°F
- 8.2** WATER QUALITY CONTROL
- 8.3** INHIBITED PROPYLENE GLYCOL
- 8.4** PRESSURE-TEMPERATURE CHART FOR R-22 REFRIGERANT
- 8.5** CHILLER CAPACITY AND DERATE CHART



8.1 OPERATIONS BELOW 48°F

- A. The chiller is never to be operated below 48°F leaving water temperature without several precautionary measures. All controls are factory adjusted for 48°F and above operations.
- B. Before readjusting the protective devices, a satisfactory antifreeze solution must be substituted for the recirculating chilled water. This mixture will consist of inhibited propylene glycol and water. Do not substitute an inhibited propylene glycol and water solution with common automotive type antifreeze. This chart outlines the glycol percentages at various water temperatures.
- C. Fluid must be tested with a hydrometer to verify proper glycol percentages for freeze protection.
- D. **DO NOT USE AUTOMOTIVE TYPE ANTI-FREEZE.**
- E. Once the antifreeze provision is satisfied, the freezestat safety switch may be readjusted. Adjust the freezestat according to this chart.

GUIDE LINES BASED ON DOWFROST INHIBITED PROPYLENE GLYCOL				
AMBIENT TEMPERATURE RANGE	FLUID TEMPERATURE RANGE	GLYCOL PERCENTAGE	WATER PERCENTAGE	FREEZE POINT
25°F to 32°F	35°F to 48°F	20%	80%	20°F
20°F to 25°F	30°F to 35°F	25%	75%	15°F
15°F to 20°F	25°F to 30°F	30%	70%	10°F
10°F to 15°F	20°F to 25°F	35%	65%	3°F
0°F to 10°F	NA	40%	60%	-5°F
-10°F to 0°F	NA	45%	55%	-16°F
-20°F to -10°F	NA	50%	50%	-28°F

- F. Adjust the low pressure safety switch according to the specifications in the chart below. **NEVER LOWER THE CUT OUT SETTING WITHOUT ADDING GLYCOL TO THE CIRCULATING SYSTEM. EVAPORATOR DAMAGE WILL RESULT AND WILL NOT BE COVERED BY THE WARRANTY.**
Note: Ambient temperature must be considered when calculating the appropriate glycol percentage. Select percentage for lowest ambient extreme.
- G. Once all safety provisions are made, the temperature control thermostat may now be lowered to the desired operating temperature.
- H. **WARNING:** do not use any type or brand of automotive antifreeze. Automotive antifreeze contains corrosion inhibitors - silicates -



designed for compatibility with the materials in automotive engines. Unfortunately, silicates can gel and cause deposits to foul and insulate heat exchanger surfaces. In your chilling system that can mean higher energy costs, high pumping costs, and possibly even shut downs for system cleaning. We recommend the use of DowFrost or Monsanto DFS-1.

LOW PRESSURESTAT AND FREEZESTAT SETTINGS			
OPERATING TEMPERATURE	LOW CUT-IN	LOW CUT-OUT	FREEZESTAT SETTING
48°F +	63#	58#	38°F
40°F	50#	35#	30°F
35°F	45#	30#	25°F
30°F	40#	25#	20°F
25°F	35#	20#	15°F
20°F	30#	15#	10°F

8.2 WATER QUALITY CONTROL

- A. Lack of proper water treatment can damage the chilling unit. The services of a competent water treatment specialist should be obtained and their recommendations followed. It is the equipment owner's responsibility to prevent damage from foreign material or inadequate water treatment.
- B. The two main things to consider for water treatment in chillers are corrosion and organism growth. Proper chemical treatment can control PH levels and algae growth. An alternative to chemical treatment is the addition of 30% inhibited propylene glycol to the water. This will help prevent organism growth and coat the heat transfer surfaces with corrosion inhibitor.

8.3 INHIBITED PROPYLENE GLYCOL

- A. To operate liquid chillers below 48°F, it is necessary to add **inhibited propylene glycol** to the circulating system to lower the freeze point and prevent damage to the cooling system. Inhibited propylene glycol contains corrosion inhibitors which are compatible with most industrial heat transfer surfaces. Inhibited propylene glycol is manufactured by:
 - Dow Chemical - "DowFrost" (1-800-258-2436)
 - Monsanto "Therminol FS" (1-800-459-2665)
 - Advantage Engineering "Thermofluid" (1-317-887-0729)
- B. Automotive anti-freeze must never be used in industrial heat transfer applications. Automotive anti-freeze contains silicate type corrosion

inhibitors designed to be compatible with automotive components. In an industrial application, the silicates will form a gel on the heat transfer surface which will result in substantial reduction in cooling capacity and is virtually impossible to remove.

- C. A hygrometer should be used on a regular basis to determine the mixture strength according to freeze point. The freeze point temperature is outlined in Section 8.1 in this manual. Water will evaporate from the mixture, and if you continue to add a premixed solution, eventually you will have too much glycol. It is necessary to add water or glycol to maintain proper freeze point temperature. The device pictured is by far the most accurate and easy to use for maintaining and checking for proper glycol levels.

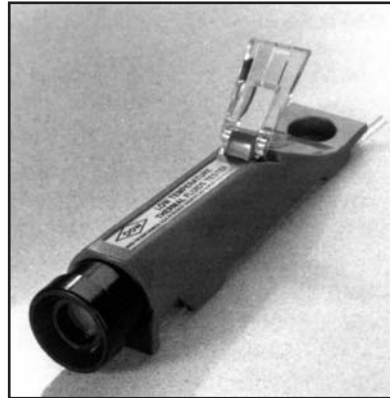

Contact:
 Misco Products:
 1-800-358-1100
 Model #7084VP

8.4 PRESSURE-TEMPERATURE CHART FOR R-22 REFRIGERANT

TEMPERATURE % OF RATED CAPACITY

60°F	—————	105%
50°F	—————	100%
45°F	—————	90%
40°F	—————	80%
35°F	—————	70%
30°F	—————	60%
25°F	—————	50%
20°F	—————	40%

These capacities are based upon 3 GPM per ton, and a minimum temperature differential of at least 10°F coolant with machine at full load for that temperature.

NOTE: Capacity will be reduced depending on propylene mixture.

8.5 CHILLER CAPACITY AND DERATE CHART

Standard chiller rating is at 50°F. For all other temperature settings, output tonnage is altered as follows:

OUTPUT TEMPERATURE °F	FULL AVAILABLE % CAPACITY
60	105%
50	100%
45	90%
40	80%
35	70%
30	60%
25	50%
20	40%
15	30% *
10	22% *
5	15% *
0	9% *
-5	5% *

NOTES:

If operation of the chiller at less than 48°F is required, an inhibited propylene glycol solution is required.

Consult factory for chiller operation below 20°F.

Ambient conditions affect air cooled chiller operation and capacity. Standard rating is at 95°F entering air temperature. For ambient air conditions greater than 95°F, chiller derating will occur. For ambient of 95-105°F, select the next larger capacity chiller. For ambient over 105°F, consult factory.

* These ranges require special options.



THIS PAGE INTENTIONALLY BLANK

END

© 2008 ADVANTAGE ENGINEERING, INC.

RE 4 4/08

